



International Patent Public No.:  
WO 2006/007772  
China Patent No.: ZL02220153.X,  
ZL200420078956.5  
US Patent No.: 7549446  
India Patent No.: 232582  
Russia Patent No.:2349819  
South Korea Patent No.:10-0914137  
Mexico Patent No.: 268581  
Australia Patent No.: 2005263257  
Philippine Patent No.: 1-2006-502553  
Taiwan Patent No.:M287896

## Multi-functional Flow Control Valve for Water Treatment Systems

52502H	(Old Model No.: F71D1)
52504H	(Old Model No.: F67D1)
62502/62602	(Old Model No.: F65D1/D3)
62504/62604	(Old Model No.: F63D1/D3)
72502/72602	(Old Model No.: F69D1/D3)
72504/72604	(Old Model No.: F68D1/D3)
82502H/82602H	(Old Model No.: F79AD/F79BD)
82504H/82604H	(Old Model No.: F82AD1/AD3)
82504BH/82604BH	(Old Model No.: F82BD1/BD3)

## Instruction Manual





Please read this manual in details  
before using this valve and keep it properly  
in order to consult in the future

0WRX.466.505

## MODEL:F63D/F65D/F67D/F68D/F69D/F71D/F79D/F82D

Before the valve put into use, please fill in the below content so as to help us to refer in the future.

### **The Program Type Setting (Operation by professional)**

When all symbols light on, press and hold  and  buttons for 5 seconds to enter the menu of valve model selection. Please set the program type in accordance with the product type. (For example, F63D1, F63D3 should be set to F63; F68D1, F68D3 should be set to F68,etc. You couldn't set to other type)

When all symbols light on, press and hold  and  buttons for 5 seconds to enter the menu of language selection.

### **Softener System Configuration**

Tank Size: Dia. \_\_\_\_\_ mm, Height \_\_\_\_\_ mm;

Resin volume \_\_\_\_\_ L; Brine Tank Capacity \_\_\_\_\_ L;

Hardness of Raw water \_\_\_\_\_ mmol/L;

Pressure of Inlet Water \_\_\_\_\_ MPa;

Control Valve Model \_\_\_\_\_ ; Number \_\_\_\_\_ ;

The Specification of Drain Line Flow Control \_\_\_\_\_ ;

Injector No. \_\_\_\_\_ ;

Water Source: Ground-water  Filtered Ground-water  Tap Water  Other \_\_\_\_\_ .

### **Parameter Set**

Parameter	Unit	Factory Default	Actual Value
Water Treatment Capacity (Meter type)	m <sup>3</sup>	80	
Service Days (Time of clock type, by days)	D.	03	
Regeneration Time	/	02 : 00	
Backwash Time	min.	10 : 00	
Brine & Slow Rinse Time	min.	60 : 00	
Brine Refill Time	min.	05 : 00	
Fast Rinse Time	min.	10 : 00	
Interval Regeneration Days	D.	30	

● If there is no special requirement when product purchase, we choose 3# drain line flow control and 5# injector as the standard configuration for F65D,F69D and F79D; 5# drain line flow control and 9# injector as the standard configuration for F63D, F68D and F82D

## Catalogue

Notice.....	3
1. Product Overview.....	4
1.1. Main Application & Applicability.....	4
1.2. Product Characteristics.....	4
1.3. Service Condition.....	5
1.4. Product Structure and Technical Parameters.....	6
1.5. Installation.....	8
2. Basic Setting & Usage.....	11
2.1. The Function and Meaning of PC Board.....	11
2.2. Basic Setting & Usage.....	11
3. Applications.....	17
3.1. Flow Chart.....	17
3.2. The Function and Connection of PC Board.....	21
A.Desinfection Derive Connector.....	21
B.Salt Shortage Alarm Device.....	21
3.3. System Configuration and Flow Rate Characteristics.....	21
3.4. Parameter Settlement.....	21
3.5. Parameter Enquiry and Setting.....	22
3.6. Trial Running.....	24
3.7. Trouble-Shooting.....	25
3.8. Assembly & Parts.....	28
4. Warranty Card.....	55

## Notice

- To ensure normal operation of the valve, please consult with professional installation or repairing personnel before use it.
- If there are any of pipeline engineering and electric works, there must be finished by professional at the time of installation.
- Do not use the control valve with the water that is unsafe or unknown quality.
- Depending on the changing of working environment and water requirement, each parameter of softener should be adjusted accordingly.
- When the water treatment capacity is too low, please check the resin. If the reason is shortage of resin, please add; if the resin is turn to reddish brown or broken, please replace.
- Test water periodically to verify that system is performing satisfactorily.
- Sodium used in the water softening process should be considered as part your overall dietary salt intake. Contact doctor if you are on a low sodium diet.
- Ensure that there is solid salt all the time in the brine tank in the course of using, when this valve is used for softening. The brine tank should be added the clean water softening salts only, at least 99.5% pure, forbidding use the small salt.
- Do not put the valve near the hot resource, high humidity, corrosive, intense magnetic field or intense librations environment. And do not leave it outside.
- Forbidden to carry the injector body. Avoid to use injector body as support to carry the system.
- Forbidden to use the brine tube or other connectors as support to carry the system.
- Please use this product under the water temperature between 5 ~ 50℃, water pressure 0.15 ~ 0.6MPa. Failure to use this product under such conditions voids the warranty.
- If the water pressure exceeds 0.6Mpa, a pressure reducing valve must be installed before the water inlet. While, if the water pressure under 0.15MPa, a booster pump must be installed before the water inlet.
- It is suggested to install PPR pipe, corrugated pipe or UPVC pipe, instead of TTLSG pipe.
- Do not let children touch or play, because carelessness operating may cause the procedure changed.
- When the attached cables of this product and transformer are changed, they must be changed to the one that is from our factory.



# 1. Product Overview

## 1.1. Main Application & Applicability

Used for softening or filtering water treatment systems

Be suitable for

Residential softening system

Residential filtering system

## 1.2. Product Characteristics

### Simple structure and reliable sealing

It adopts hermetic head faces with high degree pottery and corrosion resistance for opening and closing. It combines with Service, Backwash, Brine & Slow Rinse, Brine Refill and Fast Rinse.

### No water pass the valve in regeneration in single tank type

#### Manual function

Realize regeneration immediately by pushing  at any time.

#### Long outage indicator

If outage overrides 3days, the prompt interface of clock calibration will flash all the time. As the figure shows:

Time of Day 12 : 30
------------------------



#### LCD screen display

It is clearly understand each status which described by text.

User can select Chinese or English display interface: when

start the program, press and hold  and  for 2 seconds, then enter into the language selecting interface.

#### Buttons lock

No operations to buttons on the controller within 1 minute, button lock indicator light on which represent buttons are locked. Before operation press and hold the  and  buttons for 5 seconds to unlock. This function can avoid incorrect operation.

### Disinfection connector ( Only for softener, and it needs to be separately equipped with a disinfection device)

The valve has the disinfection connector, which can supply DC5V/200mA power output under the Brine status. It can make a part of brine water electrolyzed, producing hypochlorous acid to sterilize and disinfect the resin. (the wiring refer to P22)

### Connector of salt shortage alarm(Only for softener, and it needs to be separately equipped with a gravity meter. )

The connector is jointed with gravity meter . When the brine tank is shortage of salt, the

## MODEL:F63D/F65D/F67D/F68D/F69D/F71D/F79D/F82D

system will give the alarm and remind user to add the salt in time. ( Wiring refer to P22 )

### **Foreground mode and background mode can be selected.**

Foreground mode is suitable for user and is only can set Time of Day, Regeneration Time, Washing Time, and Feed Water Hardness, etc. Background mode can set other parameters of regeneration time. (Setting refer to P26)

### **1.3. Service Condition**

Runxin valve should be used under the below conditions:

Items		Requirement
Working conditions	Water pressure	0.15MPa ~ 0.6MPa
	Water temperature	5℃ ~ 50℃
Working environment	Environment temperature	5℃ ~ 50℃
	Relative humidity	≤95% ( 25℃ )
	Electrical facility	AC100 ~ 240V/50 ~ 60Hz
Inlet water quality	Water turbidity	Down-flow regeneration <5FTU; Up-flow regeneration <2FTU Filter <20FTU
	Free chlorine	<0.1mg/L
	Iron <sup>2+</sup>	<0.3mg/L

●When the water turbidity exceeds the conditions, a filter should be installed on the inlet of control valve.

●The requirement of free chlorine is only for softener.

MODEL:F63D/F65D/F67D/F68D/F69D/F71D/F79D/F82D

**1.4. Product Structure and Technical Parameters**

A. Product Dimension (The appearance is just for reference. It is subjected to the real product.)

F71D ( 52502H ) /F67D ( 52504H )

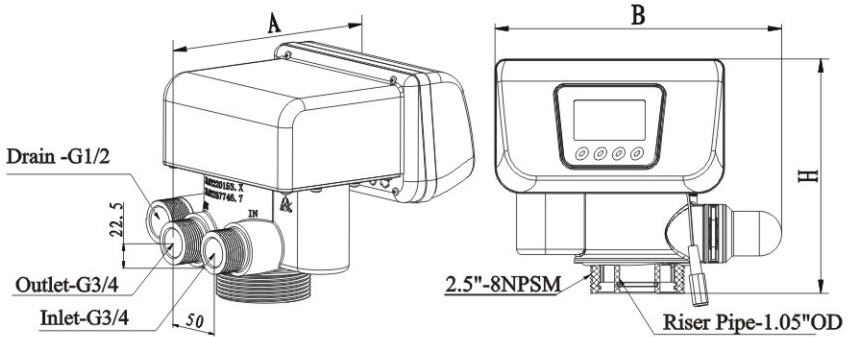

Model	A ( mm ) max	B ( mm ) max	H ( mm ) max
F71D ( 52502H )	182.5	195.5	143
F67D ( 52504H )	180	194	178.5

F65D1 ( 62502 ) /F69D1 ( 72502 )

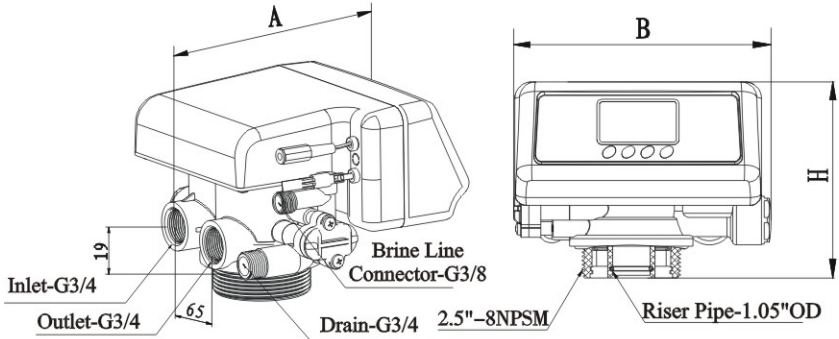

Model	A ( mm ) max	B ( mm ) max	H ( mm ) max
F65D ( 62502 )	187.3	187.8	142.8
F69D ( 72502 )	196.4	187.8	152.8

MODEL:F63D/F65D/F67D/F68D/F69D/F71D/F79D/F82D

F63D1 ( 62504 ) /F68D1 ( 72504 )

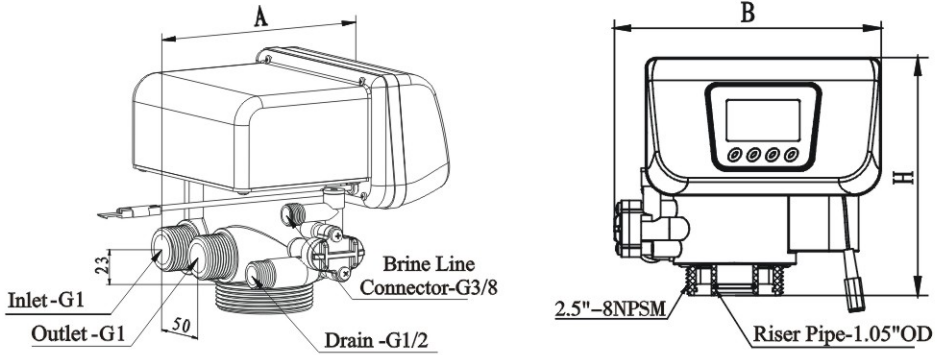

Model	A ( mm ) max	B ( mm ) max	H ( mm ) max
F63D ( 62504 )	282	198	177
F68D ( 72504 )	282	198	176.5

F79AD ( 82602H ) /F79BD ( 82602BH )

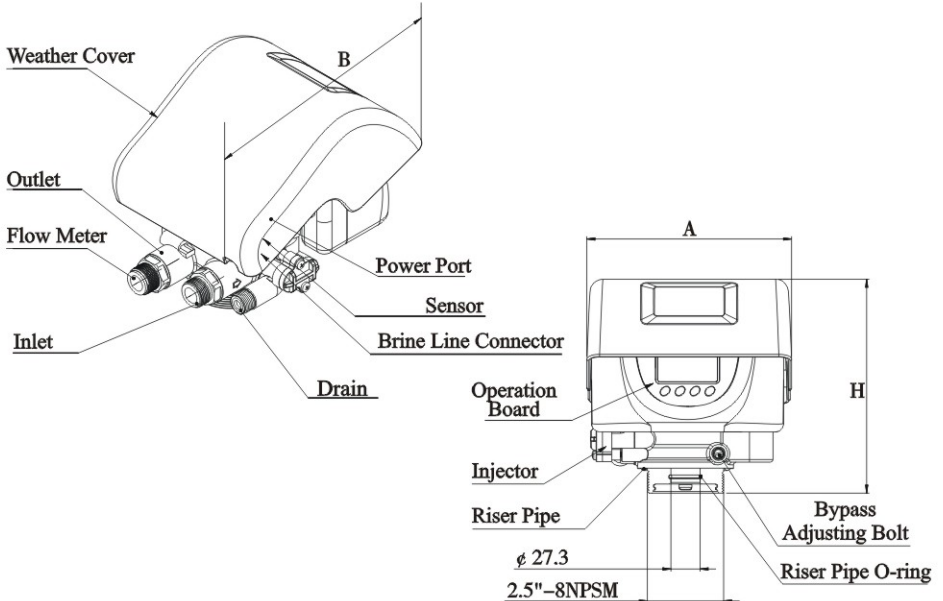

# MODEL:F63D/F65D/F67D/F68D/F69D/F71D/F79D/F82D

F82AD (82504H) /F82BD (82504BH)

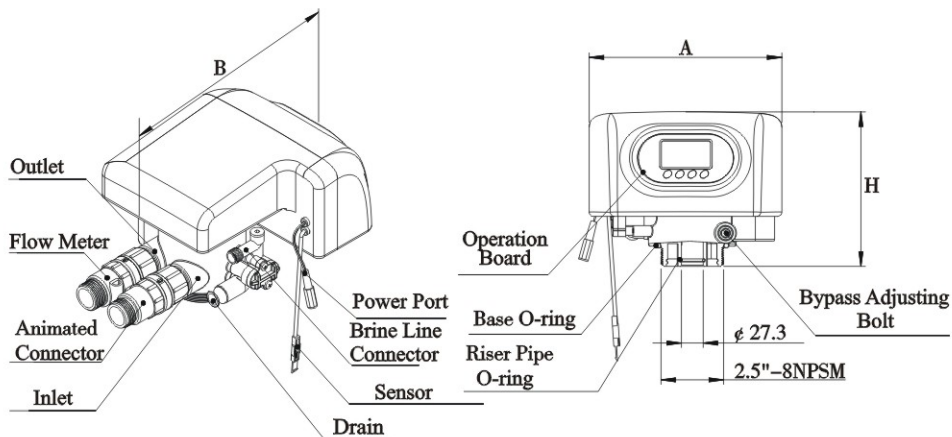

Model	A (mm) max	B (mm) max	H (mm) max	Remark
F79AD/F79BD	186	230	170	Opening Weather Cover H <sub>max</sub> =256
F82AD/F82BD	220	260	180	

## B. Technical Parameters

Transformer Output: DC12V, 1.5A

Model	Connector Size				Flow Rate m <sup>3</sup> /h @0.3MPa	Remark	
	Inlet /Outlet	Drain	Brine Line Connector	Base Riser Pipe			
F71D (52502)	3/4 " M	3/4 " M	/	2.5-8NPSM	1.05 " OD (26.7mm)	2.0	Filter
F67D(52504)	1 " F	1 " F	/			4.0	Filter
F65D(62502)	3/4 " F	3/4 " F	3/8 " M			2.0	Down-flow
F63D(62504)	1 " M	1/2 " M	3/8 " M			4.0	Down-flow
F69D(72502)	3/4 " F	3/4 " F	3/8 " M			2.0	Up-flow
F68D(72504)	1 " M	1/2 " M	3/8 " M			4.0	Up-flow
F79D(82502)	3/4 " M	3/4 " M	3/8 " M			2.0	Down-flow /Up-flow
F82D(82504)	1 " M	1/2 " M	3/8 " M			4.0	Down-flow /Up-flow

Attention: M—Male F—Female OD—Out Diameter

Above table, it only lists the Time Clock type. For the Down-flow softener, or Up-flow softener and Meter type product, they have the same connector size as the Time Clock type.



## 1.5. Installation

(Take F63D3 example)

### A. Installation notice

Before installation, read all those instructions completely. Then obtain all materials and tools needed for installation.

The installation of product, pipes and circuits, should be accomplished by professional to ensure the product can operate normally.

Perform installation according to the relative pipeline regulations and the specification of Water Inlet, Water Outlet, Drain Outlet, Brine Line Connector.

### B. Device location

- ①The filter or softener should be located close to drain.
- ②Ensure the unit is installed in enough space for operating and maintenance.
- ③Brine tank need to be close to softener
- ④The unit should be kept away the heater, and not be exposed outdoor. Sunshine or rain will cause the system damage.
- ⑤Please avoid to install the system in the Acid/Alkaline, Magnetic or strong vibration circumstance, because above factors will cause the system disorder.
- ⑥Do not install the filter or softener, drain pipeline in circumstance which temperature may drop below 5°C, or above 5°C.
- ⑦One place is recommended to install the system which cause the minimum loss in case of water leaking.

### C. Pipeline installation

#### ①Install control valve

a.As the Figure 1-1 shows, select the riser pipe with 26.7mm OD, glue the riser pipe to the bottom strainer and put it into the mineral tank, cut off the exceeding tube out of tank top opening. Plug the riser tube in case of mineral entering.

b.Fill the mineral to the tank, and the height is accordance with the design code.

c.Remove the tap covering on the central tube and check if the riser tube is on the central of tank.

d.Install the top distributor to the valve and insert the riser tube into control valve and screw tight control valve.

#### Note:

●The length of riser tube should be neither higher 2mm nor lower 5mm tank top opening height, and its top end should be rounded to avoid damage of O-ring inside the valve.

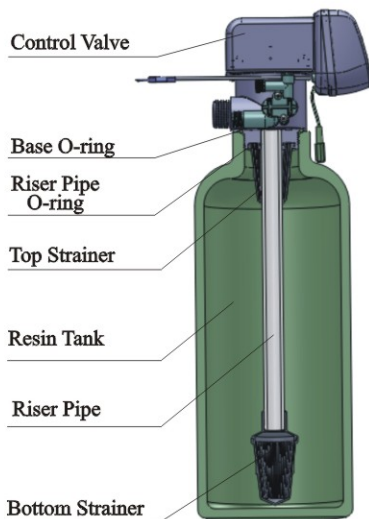

Figure 1

## MODEL:F63D/F65D/F67D/F68D/F69D/F71D/F79D/F82D

- Avoid floccules substance together with resin to fill in the mineral tank.
- Avoid O-ring inside control valve falling out while rotating it on the tank.

### ② Install animated connector

As Figure 1-2 shows, put the sealing ring into nut of animated connector, and screw in water inlet.

### ③ Install flow meter

As Figure 1-2 shows, put the sealing ring into nut of flow meter, screw in water outlet; insert the sensor into flow meter.

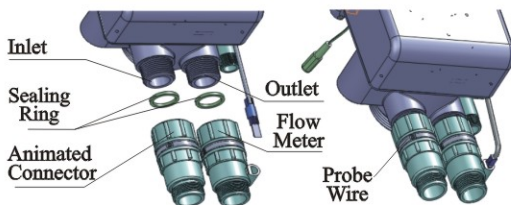

Figure 1-2

### ④ Pipeline connection

a. As Figure 1-3 shows, install a pressure gauge in water inlet.

b. Install valve A, valve B, valve C and valve D in the inlet and outlet pipeline. The valve D is sampling valve. (Or adopt F70A/F70C bypass valve).

c. Inlet pipeline should be in parallel with outlet pipeline. Support inlet and outlet pipeline with fixed holder.

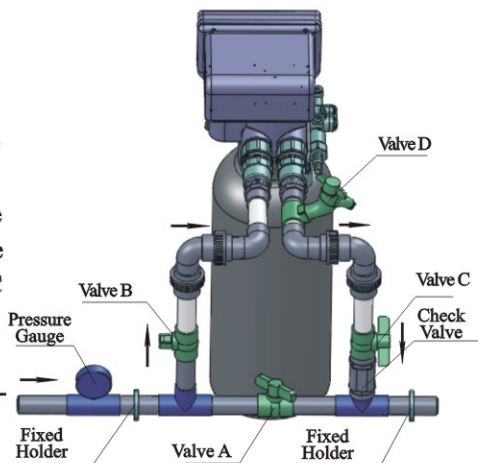

Figure 1-3

Note:

- If the water outlet or water tank is installed higher than control valve or parallel interlock system with multi-outlets, a liquid level controller must be installed in brine tank. Or else, the water in water outlet or water tank will flow backwards into brine tank when backwash.
- If making a soldered copper installation, do all sweat soldering before connecting pipes to the valve. Torch heat will damage plastic parts.
- When turning threaded pipe fittings onto plastic fitting, use care not to cross thread or broken valve.
- If the valve belongs to time clock type, there are no step ② and ③

### ⑤ Install drain pipeline

a. As the Figure 1-4 shows, slide the drain hose connector into drain outlet.

b. Insert drain line flow control into drain outlet.

c. Screw drain hose connector into drain outlet, and lock it.

d. Locate the drain hose well as the Figure 1-4 show.

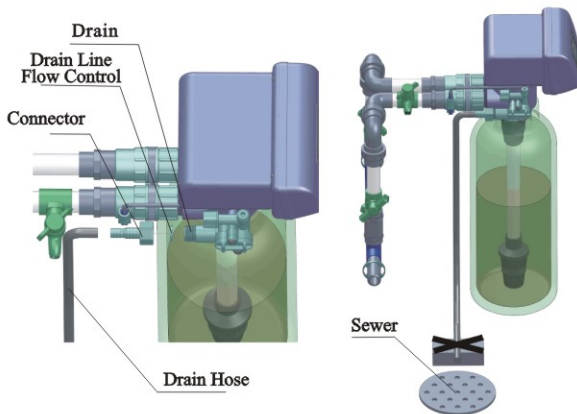

Figure 1-4

**Note:**

- Control valve should be higher than drain outlet, and be better not far from the drain hose.
- Be sure not connect drain with sewer, and leave a certain space between them, avoid wastewater be absorbing to the water treatment equipment.

⑥ Connect brine tube

- a. Slide 3/8" brine tube hose connector over end of brine tube.
- b. Insert tube bushing into the end of brine tube.
- c. Insert the red brine line flow control into valve brine line connector (Attention: cone side of control should face into valve). Insert tube bushing into the end of brine tube.
- d. Tighten brine draw hose connector onto brine line connector.
- e. Connect the other end of brine tube with the brine tank. (The liquid level controller and air-blocker should be installed in the brine tank.)

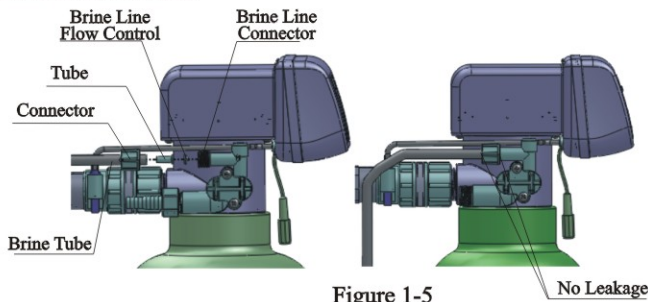

Figure 1-5

**Note:**



The brine tube and drain pipeline should not be bended or plugged; for the filter valve, there is only ①④⑤ steps

## 2. Basic Setting & Usage

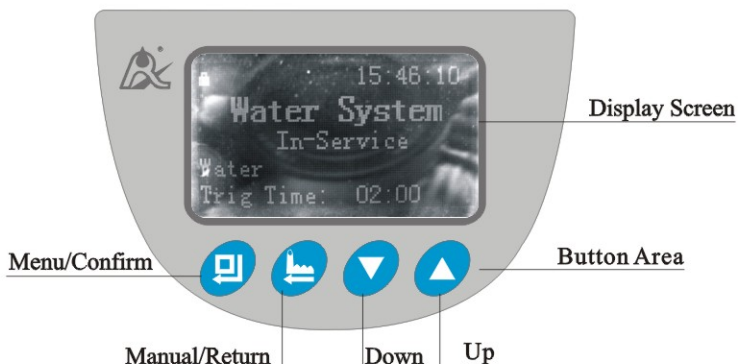
### 2.1. The Function and Meaning of PC Board



#### A. Button lock indicator

●  light on, indicate the buttons are locked. At this moment, press any single button will not work. ( Under any status, no operation in one minute,  will light on and lock the buttons)

● Solution: press and hold both  and  for 5 seconds until the  light off.



#### B. Menu/Confirm button



● In menu mode, press  and then enter program display mode ,viewing all values.

● In program display mode, press  and enter program set mode, adjusting all values.

● Press  after all program are set, and then the voice “Di” means all setting are success and return program display mode.

#### C. Manual/Return button



● Press  in any status, it can proceed to next step. (Example: Press  in Service status, it will start regeneration cycles instantly; Press  while it is in Backwash status, it will end backwash and go to Brine & Slow Rinse at once.)

● Press  in program display mode, and it will return in Service; Press  in program set mode, and it will return program display mode.

● Press  while adjusting the value, then it will return program display mode directly without saving value.

#### D. Down and Up

● In program display mode, press  or  to view all values.

● In program set mode, press  or  to adjust values.

● Press and hold both  and  for 5 seconds to lift the Button Lock status.



# MODEL:F63D/F65D/F67D/F68D/F69D/F71D/F79D/F82D



## 2.2. Basic Setting & Usage

### A.Parameter Specification

Item	Parameter Set Range	Factory Default	Instruction
Time of Day	00:00 ~ 23:59	Current Value	It's for all residential valve.
Rinsing Time	00:00 ~ 23:59	02:00	It's only for F67/F71 Residential Filter.
Regeneration Time	00:00 ~ 23:59	02:00	It's only for F63 /F65 /F68 /F69 /F79 /F82 Residential Softener.
Feed Water Hardness	50 ~ 400mg/L	150mg/L	It's only for F63 /F65 /F68 /F69 /F79/F82 Meter Type Residential Valve.

#### Illustration:

● In the display screen, F67/F71/F63/F65/F68/F69/F79/F82 is equal to F67D/F71D/F63D/F65D/F68D/F69D/F79D/F82D.

● Press and hold both  and  for more than 2 seconds after power on, then enter into the language selecting interface.

### B.Process Display

#### ①User Mode

After power on, L1 and L2 interface will show 3 seconds separately, and then enter into user mode.



```
*****
Residential Valve
*****
```

#### ②F67D/F71D process display

12:30:25 System in Service Remaining: 30 days Rising Time: 02:00	02:08:00 In Backwash... Remaining: 2 min.	02:17:25 In Fast Rinse... Remaining: 3 min.	Motor Running.....
Service Status	Backwash Status	Fast Rinse Statuses	Motor Running

#### Illustration:

Working process of F67D/F71D: Service→ Backwash→ Fast Rinse→ Service (So circulate).

#### ③F63D1/ F65D1/ F68D1/ F69D1/ F79D1/ F82D1 Time Clock type Softener process display

12:30:25 System in Service Remaining: 30 days Regen. Time: 02:00	02:08:00 In Backwash... Remaining: 2 min.	02:40:25 In B. S. Rinse... Up-flow Regeneration Remaining: 30 min.	03:15:50 In Brine Refill... Remaining: 5 min.
Service Status	Backwash Status	Brine & Slow Rinse Status	Brine Refill Status



## MODEL:F63D/F65D/F67D/F68D/F69D/F71D/F79D/F82D

03:25:50 In Fast Rinse... Remaining: 3 min.	Motor Running.....
---	--------------------

Fast Rinse Status

Motor Running

### Illustration:

● Under Brine & Slow Rinse status, for F63D/F65D, the display screen shows “Down-flow Regeneration” ; for F68D/F69D, it shows “Up-flow Regeneration” ; for F79/F82 D, it shows “Down-flow Regeneration” or “Up-flow Regeneration” .

● Working process of F63D/F65D/F68D/F69D/F79D/F82D Time Clock type Softener: Service → Backwash → Brine & Slow Rinse → Brine Refill → Fast Rinse → Service (So circulate).

### ④ F63D3/F65D3/F68D3/F69D3/F79D3/F82D3 Meter type Softener process display

12:30:25 System in Service Remaining: 2.56m <sup>3</sup> Cur. F.R.: 3.65m <sup>3</sup> /h	12:30:35 System in Service Regen. Time: 02:00	02:08:00 In Backwash... Remaining: 2 min.	02:40:25 In B. S. Rinse... Up-flow Regeneration Remaining: 30 min.
--	--	---	---

Service Status 1

Service Status 2

Backwash Status

Brine & Slow Rinse Status

03:15:50 In Brine Refill... Remaining: 5 min.	03:25:50 In Fast Rinse... Remaining: 3 min.	Motor Running.....
---	---	--------------------

Brine Refill Status

Fast Rinse Status

Motor Running

### Illustration:

● Under Brine & Slow Rinse status, for F63D/F65D, the F63D/F65D display screen shows “Down-flow Regeneration” ; for F68D/F69D, it shows “Up-flow Regeneration” ; For F79D/F82D, it shows “Down-flow Regeneration” or “Up-flow Regeneration” .

● Working process of F63D/F65D/F68D/F69D/F79D/F82D Time Clock type Softener: Service → Backwash → Brine & Slow Rinse → Brine Refill → Fast Rinse → Service (so circulate).

### C. Basic Usage

After being accomplished installation, parameter setting and trial running, the valve could be put into use. In order to ensure the quality of outlet water can reach the requirement, the user should complete the below works:

① Ensure that there is solid salt all the time in the brine tank in the course of using when this valve is used for softening. The brine tank should be added the clean water softening salts only, at least 99.5% pure, forbidding use the small salt and iodized salt.





















## MODEL:F63D/F65D/F67D/F68D/F69D/F71D/F79D/F82D

②When the outlet water hardness is higher, please press the  and the valve will temporary regenerate again. (It will not affect the original set operation cycle).

③When the feed water hardness change a lot, you can adjust the feed water hardness as follow. (Refer to the third point of “User Setting” )





















### D.User Setting

#### ①F67D/F71D Residential Filter setting items and process

Items	Process steps	Symbol
Time Of Day	<p>When  light on, press and hold both  and  for 5 second until  light off.</p> <ol style="list-style-type: none"> <li>1. Press  and enter into the interface of “Set Filter Para.” ,as the figure J1 shows. The item of “Set Time of Day” will be selected by system automatically.</li> <li>2. Then press , and the setting interface will display as the figure J2; the hour value ” 12” flash, through  or  to adjust the hour value.</li> <li>3. Then press  again, the minute value “30” flash, through  or  to adjust the minute value.</li> <li>4. Lastly, press  and hear a sound “Di” , then finish adjustment.</li> </ol>	<div style="border: 1px solid black; padding: 5px; margin-bottom: 10px;"> <p>Set Filter Para.                      » Set Time of Day                      Set Rinsing Time</p> </div> <p style="text-align: center;">J1</p> <div style="border: 1px solid black; padding: 5px;"> <p>Set Time of Day                      12 : 30</p> </div> <p style="text-align: center;">J2</p>
Rin-sing Time	<ol style="list-style-type: none"> <li>1. Press  and enter into the interface of “Set Filter Para.” ,as the figure J1 shows.</li> <li>2. Press  and select the item of “Set Rinsing Time” ; Then  press , the setting interface will show as the figure J3; the hour value 02 flash, through  or  to adjust the hour value.</li> <li>3. Then press , the minute value “00” flash, through  or  to adjust the minute value.</li> <li>4. Lastly, press  and hear a sound “Di” , then finish adjustment.</li> </ol>	<div style="border: 1px solid black; padding: 5px;"> <p>Set Filter Para.                      Set Time of Day                      » Set Rinsing Time</p> </div> <p style="text-align: center;">J3</p>



























MODEL:F63D/F65D/F67D/F68D/F69D/F71D/F79D/F82D

②F63D1/F65D1/F68D1/F69D1/F79D1/F82D1 Time Clock Type Residential Softener setting items and process

Items	Process steps	Symbol
Time of Day	<p>When  light on, press and hold  and for 5 seconds until the  light off.</p> <ol style="list-style-type: none"> <li>1. Press  and enter into the interface of “T. Softener Para. Set”, as the figure SR1 shows. The item of “Set Time of Day” will be selected by system automatically.</li> <li>2. Then press the “”, and the setting interface will display as the figure SR2; the hour value “12” flash, through  or  to adjust the hour value.</li> <li>3. Then press  again, the minute value “30” flash, through  or  to adjust the minute value.</li> <li>4. Lastly, press  and hear a sound “Di”, then finish adjustment.</li> </ol>	<div data-bbox="728 359 952 494" style="border: 1px solid black; padding: 5px; margin-bottom: 10px;">                     T. Softener Para. Set                      &gt; Set Time of Day                      Set Regen. Time                 </div> <p align="center">SR1</p> <div data-bbox="728 622 952 758" style="border: 1px solid black; padding: 5px;">                     Set Time of Day                      12 : 30                 </div> <p align="center">SR2</p>
Regeneration Time	<ol style="list-style-type: none"> <li>1. Press  and enter into the interface of “T. Softener Para. Set”, as the figure SR1 shows.</li> <li>2. Press  and select the item of “Set Regen. Time”; then press , the setting interface will display as the figure SR3; hour value “02” flash, through  or  to adjust the hour value.</li> <li>3. Then press , the minute value “00” flash, through  or  to adjust the minute value.</li> <li>4. Lastly, press  and hear a sound “Di”, then finish adjustment.</li> </ol>	<div data-bbox="728 1109 952 1244" style="border: 1px solid black; padding: 5px;">                     Set Regen. Time                      02 : 00                 </div> <p align="center">SR3</p>

MODEL:F63D/F65D/F67D/F68D/F69D/F71D/F79D/F82D

③F63D3/F65D3/F68D3/F69D3/F79D3/F82D3 Meter Type Residential Softener setting items and process

Items	Process steps	Symbol
Time of Day	<p>When  light on, press and hold  and  for 5 seconds until the  light off.</p> <p>1. Press  and enter into the interface of “M. Softener Para. Set”, as the figure LR1 shows. The item of “Set Time of Day” will be selected by system automatically.</p> <p>2. Then press the “”, and the setting interface will display as the figure LR2; the hour value “12” flash, through  or  to adjust the hour value.</p> <p>3. Then press  again, the minute value “30” flash, through  or  to adjust the minute value.</p> <p>4. Lastly, press  and hear a sound “Di”, then finish adjustment.</p>	<div data-bbox="718 288 944 469" style="border: 1px solid black; padding: 5px;">                     M. Softener Para. Set                      » Set Time of Day                      Set Regen. Time                      Set Water Hardness                 </div> <p align="center">LR1</p> <div data-bbox="718 549 944 687" style="border: 1px solid black; padding: 5px;">                     Set Time of Day                      12 : 30                 </div> <p align="center">LR2</p>
Regeneration Time	<p>1. Press  and enter into the interface of “M. Softener Para. Set”, as the figure LR1 shows.</p> <p>2. Press  and select the item of “Set Regen. Time”; then press , the setting interface will display as the figure LR3; hour value “02” flash, through  or  to adjust the hour value.</p> <p>3. Then press , the minute value “00” flash, through  or  to adjust the minute value.</p> <p>4. Lastly, press  and hear a sound “Di”, then finish adjustment.</p>	<div data-bbox="718 895 944 1034" style="border: 1px solid black; padding: 5px;">                     Set Regen. Time                      02 : 00                 </div> <p align="center">LR3</p>
Water Hardness	<p>1. Press  and enter into the interface of “M. Softener Para. Set”, as the figure LR1 shows.</p> <p>2. Press  twice and select the item of “Set Water Hardness”; then press , the setting interface will display as the figure LR4; hardness value 150” flash, through  or  to adjust the hardness value.</p> <p>3. Lastly, press  and hear a sound “Di”, then finish adjustment.</p>	<div data-bbox="718 1225 944 1364" style="border: 1px solid black; padding: 5px;">                     Set Water Hardness                      150mg/L                 </div> <p align="center">LR4</p>

### 3. Applications

#### 3.1. Flow Chart

##### A. Softener Flow Chart

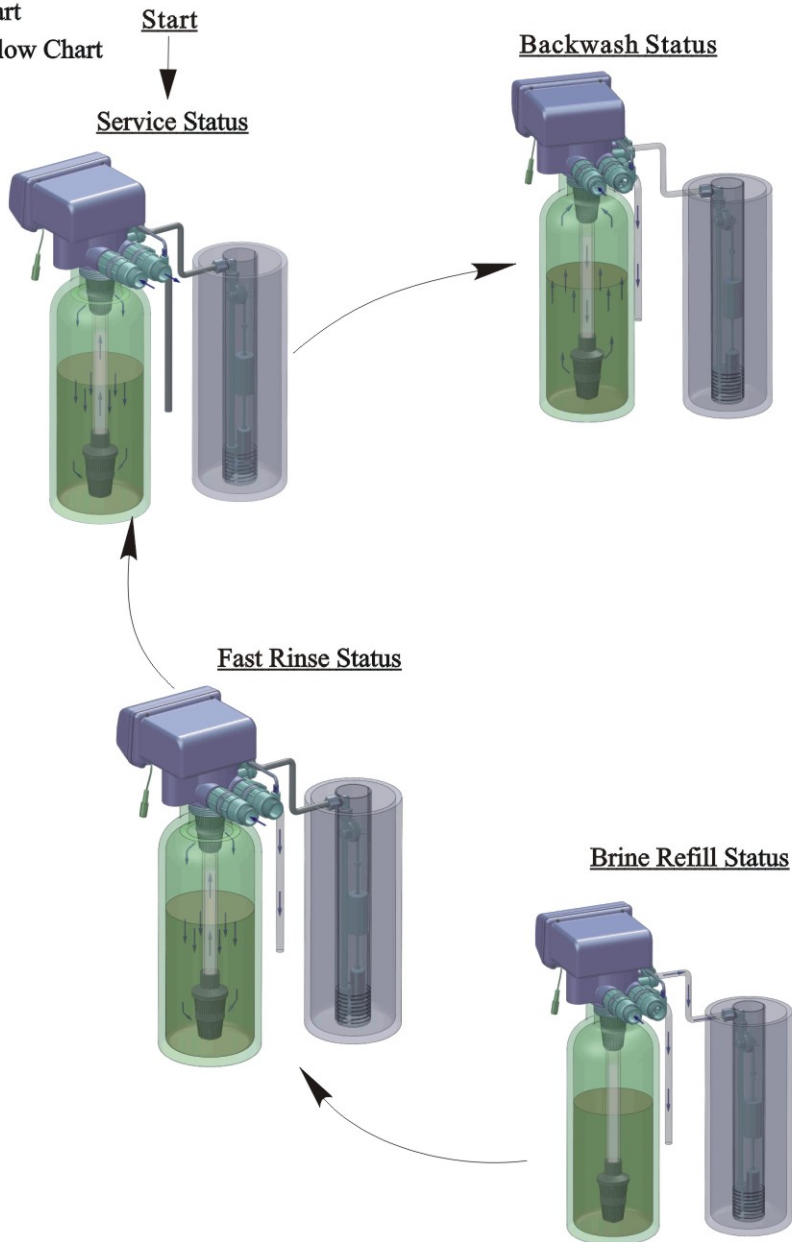



Up-flow Regeneration  
Brine Draw Status

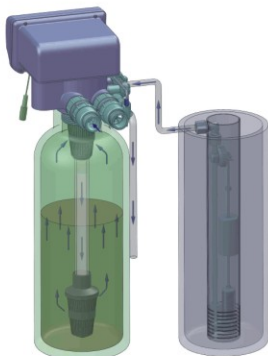

Slow Rinse Status

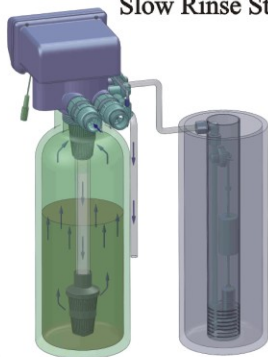

Down-flow Regeneration  
Brine Draw Status

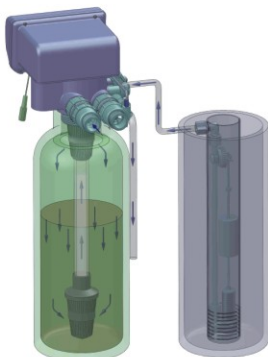

Slow Rinse Status

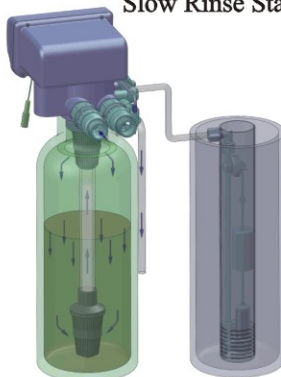

B. Filter Flow Chart

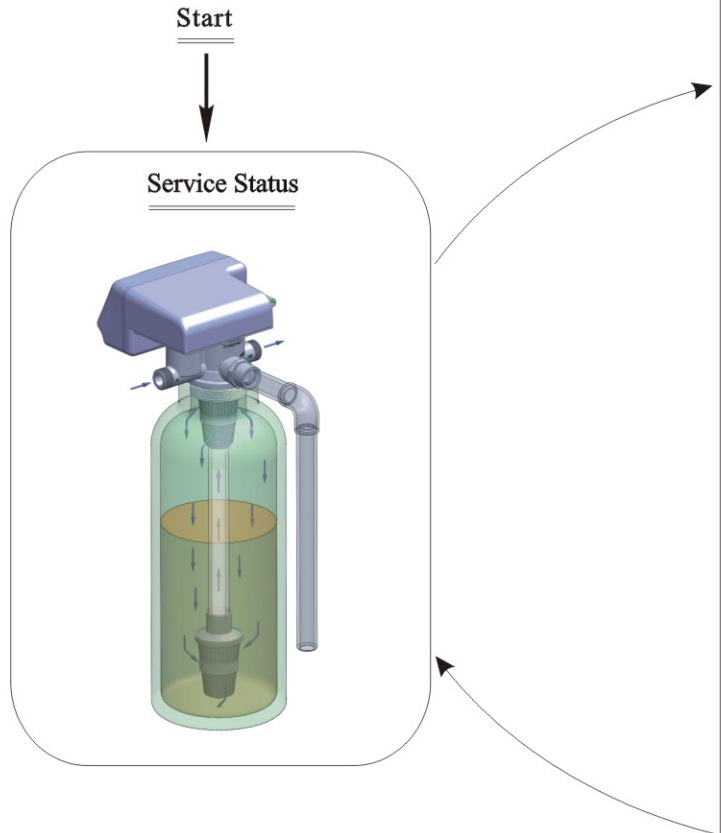

Backwash Status

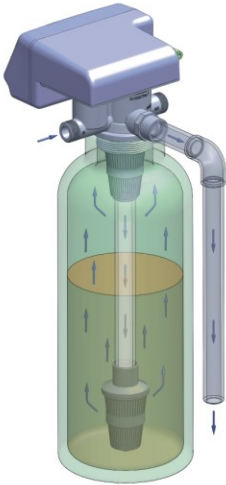

Fast Rinse Status

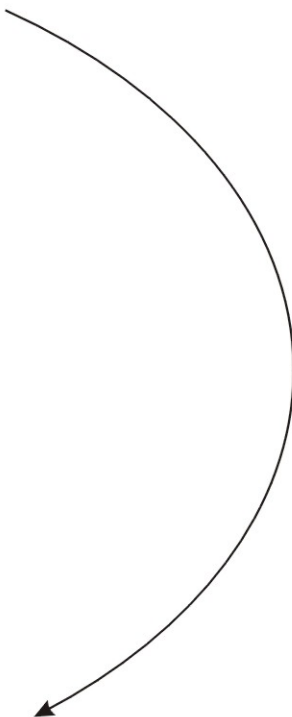
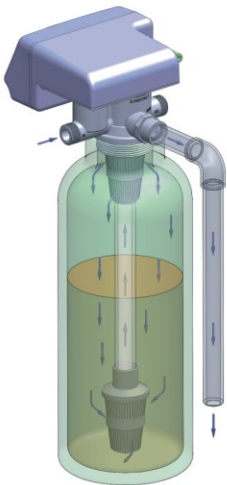

## MODEL:F63D/F65D/F67D/F68D/F69D/F71D/F79D/F82D

### 3.2. The Function and Connection of PC Board

Open the front cover of control valve, you will see the main control board and connection port as below:

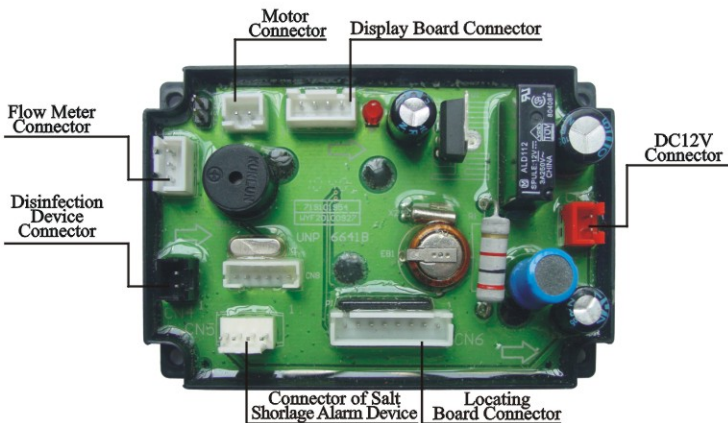

Function	Application	Explanation
Disinfection connector	It is used for disinfecting resin when softener in regeneration.	Under the Brine & Slow Rinse status, It can make a part of brine water electrolyzed, producing hypochlorous acid to sterilize and disinfect the resin.
Connector of salt shortage alarm	It is used for checking whether the salt is enough in the brine tank.	When the brine tank is shortage of salt, the system will give the alarm and remind user to add the salt in time.

#### A. Disinfection device connector

If it is need to connect the disinfection device, the ground electrode of the disinfection device and power line should be connected to the “CND” and “+5V” separately, which are in the CN4 plug. The wiring refer to the figure 1.

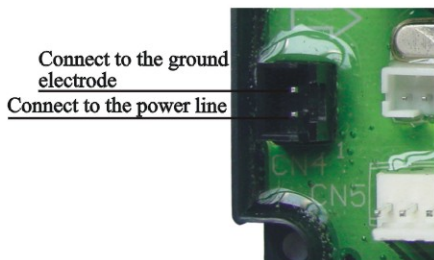

Figure 1

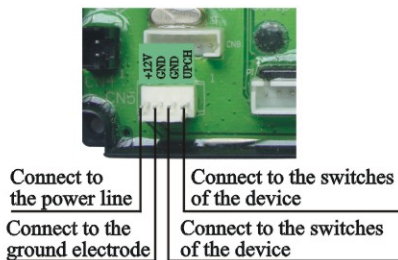

Figure 2

#### B. Salt shortage alarm device

If it is need to connect the salt shortage alarm device, the ground electrode of the salt shortage alarm device and positive power should be connected to the “GND” and “+12V” separately, which are in the CN5 plug. Besides, the switches of the device should be connected to the “GND” and “UPCH” separately. The wiring refer to the figure 2.

## MODEL:F63D/F65D/F67D/F68D/F69D/F71D/F79D/F82D

### 3.3. System Configuration and Flow Rate Characteristics

#### A. Product Configuration

##### 1) Softener valve configuration with tank, resin volume, brine tank and injector

Tank Size (mm)	Resin Volume (L)	Flow Rate (t/h)	Brine Tank Size (mm)	The Minimum Salt Consumption for Regeneration (Kg)	Injector Model
φ 180 × 1130	16	0.5	φ 250 × 520	2.40	6302
φ 205 × 1300	25	0.7	φ 390 × 810	4.00	6303
φ 255 × 1390	40	1.2	φ 390 × 810	6.00	6305
φ 300 × 1650	60	1.8	φ 450 × 940	9.00	6306
φ 355 × 1650	100	2.5	φ 500 × 1060	15.00	6308
φ 400 × 1650	120	3.5	φ 550 × 1160	18.00	6309
φ 450 × 1650	150	4.5	φ 550 × 1160	22.50	6310

Attention: The flow rate calculation is based on linear velocity 25m/hr; the minimum salt consumption for regeneration calculation is based on salt consumption 150g / L( Resin).

##### 2) Filter valve configuration with tank, resin volume, brine tank and injector

Tank Size (mm)	Volume of Filter Material	Carbon Filter		Sand Filter	
		Filtering Flow Rate	Backwash Flow Rate	Filtering Flow Rate	Backwash Flow Rate
mm	L	m <sup>3</sup> /h	m <sup>3</sup> /h	m <sup>3</sup> /h	m <sup>3</sup> /h
φ 180 × 1130	16	0.3	0.9	0.6	1.3
φ 205 × 1300	25	0.4	1.1	0.8	1.7
φ 255 × 1390	40	0.6	1.7	1.2	2.6
φ 300 × 1390	60	0.8	2.5	1.7	3.8
φ 355 × 1650	100	1.2	3.4	2.4	5.2
φ 400 × 1650	120	1.5	4.5	3.1	6.8

Attention: the filtering flow rate of carbon filter is calculated based on the 12m/h service rate; the backwash flow rate is calculated based on the 10L/(m<sup>2</sup>×s) backwash intensity; the filtering flow rate of sand filter is calculated based on the 25m/h service rate; the backwash flow rate is calculated based on the 15L/(m<sup>2</sup>×s) backwash intensity;



## MODEL:F63D/F65D/F67D/F68D/F69D/F71D/F79D/F82D

### **B. Flow Rate characteristic**

#### 1) . Injector parameter table

Inlet Pressure	Draw Rate ( L/M )									
MPa	6301 Coffee	6302 Pink	6303 Yellow	6304 Blue	6305 White	6306 Black	6307 Purple	6308 Red	6309 Green	6310 Orange
0.15	0.81	1.12	1.58	2.21	2.45	3.30	3.44	4.08	5.19	5.69
0.20	0.95	1.41	1.87	2.53	2.89	3.88	4.21	4.83	5.36	6.80
0.25	0.99	1.61	2.08	2.79	3.30	4.30	4.66	5.39	6.86	7.65
0.30	1.30	1.81	2.18	3.05	3.66	4.74	5.15	5.95	7.50	8.60
0.35	1.45	1.96	2.39	3.27	3.94	5.02	5.55	6.51	8.30	9.57
0.40	1.56	2.12	2.55	3.50	4.25	5.41	5.88	6.77	8.74	9.90

#### 2) . Configuration for Standard Injector and Drain Line Flow Control

Tank Dia. Mm	Injector Model	Injector Color	Draw Rate	Slow Rinse	Brine Refill	DLFC	Backwash/ Fast Rinse
			L/m	L/m	L/m		L/m
150	6301	Coffee	1.30	0.91	3.0	1#	4.7
175	6302	Pink	1.81	1.32	3.7	1#	4.7
200	6303	Yellow	2.18	1.73	3.8	2#	8.0
225	6304	Blue	3.05	2.14	3.3	2#	8.0
250	6305	White	3.66	2.81	4.3	3#	14.4
300	6306	Black	4.74	3.32	4.2	3#	14.4
325	6307	Purple	5.15	3.55	4.1	4#	22.8
350	6308	Red	5.95	4.0	4.0	4#	22.8
400	6309	Green	7.50	5.13	4.0	5#	26.4
450	6310	Orange	8.60	5.98	3.9	5#	26.4

Remark: Above data for the product configuration and relevant characteristics are only for reference. When put in practice, please subject to the different requirements of raw water hardness and application.

## MODEL:F63D/F65D/F67D/F68D/F69D/F71D/F79D/F82D

### 3.4. Parameter settlement

①Regeneration time: The whole cycle for generation is about two hours. Please try to set up the regeneration time when you don't need water according to the actual situation.

( Only for Meter Type )

② Water treatment capacity  $Q=V_R \times E / ( Y_d \times k )$

In this formula,  $V_R$ —Resin Volume (  $m^3$  )

$E$ —Resin working exchange capability (  $mol/m^3$  )

$Y_d$ —Hardness of Inlet Water (  $mol/m^3$  )

$k$ —Security factor, always take 1.2 ~ 2. it is related to the hardness of inlet water: the higher the hardness is, the bigger the K is.

③Backwash time: Generally, It is suggested to be set 10 ~ 15 minutes. The higher the turbidity is, the longer backwash time can be set. However, if the turbidity is more than 5FTU, it should be better to install a filter in front of the exchanger.

④Brine& Slow rinse time= Brine draw time+ Slow rinse time (Slow rinse time is also named replacement time)

a ) Brine draw time= $60 \times V_z / (S \times v)$  (min)

$$V_z = M_{oz} / (C \times \rho \times 103) \text{ (m}^3\text{)}$$

In this formula,  $V_z$ —The volume of regeneration liquid,  $m^3$

$S$ —The sectional area of exchanger,  $m^2$

$v$ —The rate of regeneration liquid, m/h

$M_{oz}$ —The dosage of 100% pure reagent for once regeneration, kg

$C$ —The concentration of regeneration liquid, %

$\rho$ —The density of regeneration liquid

$$M_{oz} = VREkM / (\varepsilon \times 1000) \text{ (kg)}$$

In this formula,  $V_R$ —Resin Volume,  $m^3$

$E$ —Resin working exchange capability,  $mol/m^3$

$k$ —The proportional consumption of reagent for down-flow regeneration,  $k$  takes 2 ~ 3.5; for up-flow regeneration,  $k$  takes 1.2 ~ 1.8

$M$ —The reagent molar mass, NaCl is 58.5

$\varepsilon$ —The purity of reagent; usually, the purity of NaCl in salt is 95%~98%

b ) Slow rinse time= Slow rinse volume/ Slow rinse rate (minute)

Generally, the volume for slow rinse is 0.5 ~ 1 times as much as the resin volume.

⑤ Brine refill time=Brine refill volume/ Brine refill rate(minute)

The brine refill volume is equal to the total salt solution consumption for regeneration. Different inlet water pressure can make different brine refill speed. It is suggested to lengthen 1~2 minutes of calculated brine refilling time to make sure there is enough water in tank.

( The condition is that there is a level controller installed in the brine tank )

## MODEL:F63D/F65D/F67D/F68D/F69D/F71D/F79D/F82D

### ⑥ Fast rinse time= Fast rinse volume/ Fast rinse rate(minute)

Generally, the water for fast rinse is 3 ~ 6 times of resin volume. It is suggested to be set 10 ~ 12 minutes, but subject to the outlet water reaching the requirement.



### ⑦Set up interval backwash times ( Only for F68, F69, F79, F82)

When the turbidity of raw water is higher, the interval backwash time could be set F-00. That is, backwash in each regeneration; when the turbidity is lower, the interval backwash time could be set F-01(or other number value), it is to say that backwash in every two regeneration. Thus, Service→ Brine & Slow rinse →Brine refill→ Fast rinse→ Service→ Backwash →Brine & Slow rinse →Brine refill →Fast rinse.

The above calculation of parameters for each step is only for reference.

## 3.5. Parameter Enquiry and Setting

### A. Enter into Background Mode

Within 6 seconds of the L1, L2 displaying, press and hold  and  for more than 2seconds to enter the Background setting menu. The interface as the H1 shows (including H1-1, H1-2, and H1-3)

### B. Setting Parameters





Under the Background Mode, you can set the parameters as below:





Mode, Valve Model, Control Type, Resin Volume, Interval Regeneration Time, Backwash Time, Brine & Slow Rinse Time, Brine Refill Time, Fast Rinse time, Service Time, Brine Draw Type, etc.





» Mode-Softener Mode Set Valve Model—F79 Set Type—Meter Type Resin Volume—8L ↓	» Set B.D. Type-Up-Flow Interval R. D.—30 days Set B.W. Time-2 min. Set B.S. R.T.-30 min.	» Set B.W. Time-2 min. Set B.S. R.T.-30 min. Set B.R. Time-5 min. Set F.R. Time-3 min. ↓	
H1-1	H1-2	H1-3	
Set Mode <input type="radio"/> Filter Mode <input checked="" type="radio"/> Softener Mode	Set Valve Model <input type="radio"/> F69 <input type="radio"/> F82 <input checked="" type="radio"/> F79	Set Type <input type="radio"/> Time Clock Type <input checked="" type="radio"/> Meter Type	Set Resin Volume 8L
A1	A2	A3	A4





## MODEL:F63D/F65D/F67D/F68D/F69D/F71D/F79D/F82D





Set B.D. Type ⊕ Up-Flow ○ Down-Flow	Interval R. D. 30 days	Backwash Time 2 min.	B. S. Rinse Time 30 min.
A5	A6	A7	A8
Brine Refill Time 5 min.	Fast Rinse Time 3 min.	Set Valve Model ⊕ F71 ○ F67	Service Days 30 days
A9	A10	A11	A12





① In the H1 interface, select the “Mode” and press “”, as the figure A1 shows. Press “” or “” to select the mode that you need. After that, Press “” to save the setting and turn back to H1; or press “” to turn back to H1 without saving the setting.

② In the H1 interface, select “Set Valve Model” and press “”, as the figure A2 shows. Press “” or “” to select the matched valve model. Press “” to save the setting and turn back to H1; or press “” to turn back to H1 without saving the setting.

③ In the H1 interface, select “Set Type” and press “”, as the figure A3 shows. Press “” or “” to select the control type that you need. Press “” to save the setting and turn back to H1; or press “” to turn back to H1 without saving the setting.

④ In the H1 interface, select “Resin Volume” and press “”, as the figure A4 shows. Press “” or “” to select the matched resin volume. Press “” to save the setting and turn back to H1; or press “” to turn back to H1 without saving the setting.



⑤ In the H1 interface, select “Set B.D. Type” and press “”, as the figure A5 shows. Press “” or “” to select the brine draw type that you need. Press “” to save the setting and turn back to H1; or press “” to turn back to H1 without saving the setting. (This item is only for F79 and F82 product)



⑥ In the H1 interface, select “Interval R. D.” and press “”, as the figure A6 shows. Press “” or “” to select the interval regeneration day that you need. Press “” to save the setting and turn back to H1; or press “” to turn







## MODEL:F63D/F65D/F67D/F68D/F69D/F71D/F79D/F82D



back to H1 without saving the setting.



⑦ In the H1 interface, select “Set B.W. Time” and press “”, as the figure A7 shows. Press “” or “” to select the backwash time that you need.



Press “” to save the setting and turn back to H1; or press “” to turn back to H1 without saving the setting.



⑧ In the H1 interface, select “Set B.S. R.T.” and press “”, as the figure A8 shows. Press “” or “” to select the brine & slow rinse time that you need.

Press “” to save the setting and turn back to H1; or press “” to turn back to H1 without saving the setting.



⑨ In the H1 interface, select “Set B.R. Time” and press “”, as the figure A9 shows. Press “” or “” to select the brine refill time that you need. Press



“” to save the setting and turn back to H1; or press “” to turn back to H1 without saving the setting.



⑩ In the H1 interface, select “Set F.R. Time” and press “”, as the figure A10 shows. Press “” or “” to select the fast rinse time that you need. Press

“” to save the setting and turn back to H1; or press “” to turn back to H1 without saving the setting.

⑪ In the H1 interface, if the mode is “Filter Mode”, then press “” and enter “Set Valve Model” menu, as the figure A11 shows. Press “” or “” to

select the valve type that you need. Press “” to save the setting and turn back to H1; or press “” to turn back to H1 without saving the setting.

⑫ In the H1 interface, if the mode is “Filter Mode” or the “Set Type” of “Softener Mode” is “Time Clock Type”, it has to select the “Service Days”. Choose the “Service Days” and press “”, as the figure A12 shows. Press “” or “”

to select the service days that you need. Press “” to save the setting and turn back to H1; or press “” to turn back to H1 without saving the setting.





### Special Note:

All above parameters should be set in accordance with the control valve, or else, it may be hardly to realize the functions.



### 3.6. Trial running

After installing the multi-functional flow control valve on the resin tank with the connected pipes, as well as setting up the relevant parameter, please conduct the trial running as follows:

- A. Fill the brine tank with the planned amount of water and adjust the air check valve. Then add solid salt to the tank and dissolve the salt as much as possible.
- B. Switch on power. Press  and go in the Backwash position; slowly open the inlet valve B to 1/4 position, making the water flow into the resin tank; you can hear the sound of air-out from the drain pipeline. After all air is out of pipeline, then open inlet valve B completely and clean the foreign materials in the resin tank until the outlet water is clean. It will take 8 ~ 10 minutes to finish the whole process.
- C. Press , turning the position from Backwash to Brine& Slow Rinse; enter in the process of Brine& Slow Rinse. The air check valve close when control valve finished sucking brine, then slow rinse start to work. It is about 60 ~ 65minutes for whole process.
- D. Press  to Brine refill position, the brine tank is being refilled with water to the required level. It takes about 5 ~ 6minutes, then add solid salt to the brine tank.
- E. Press , turning to Fast Rinse position and start to fast rinse. After 10 ~ 15minutes, take out some outlet water for testing; if the water hardness reach the requirement, and the chloridion in water is almost the same compared with the inlet water, then go to the next step.
- F. Press , making the control valve return to Service Status and start to running.

#### Note :

- When the control valve enters into the regeneration status, all program can be finished automatically according to the setting time; if you want one of steps terminated early, you can press .
- If water inflow too fast, the media in tank will be damaged. When water inflow slowly, there is a sound of air emptying from drain pipeline.
- After changing resin, please empty air in the resin according to the above Step B.
- In the process of trial running, please check the water situation in all position, ensuring there are no resin leakage.
- The time for Backwash, Brine& Slow Rinse, Brine Refill and Fast Rinse position can be set and executed according to the calculation in the formula or suggestions from the control valve suppliers.

MODEL:F63D/F65D/F67D/F68D/F69D/F71D/F79D/F82D

3.7. Trouble-Shooting

A. Control Valve Fault

Problem	Cause	Correction
1. Softener fails to regenerate.	A. Electrical service to unit has been interrupted. B. Regeneration cycles set incorrect. C. Controller is defective. D. Motor fails to work.	A. Assure permanent electrical service (Check fuse, plug, pull chain or switch). B. Reset regeneration cycles. C. Replace controller. D. Replace motor.
2. Regeneration time is not correct.	A. Time of Day not set correctly. B. Power failure more than 3 days.	A. Check program and reset time of day. B. Reset time of day.
3. Softener supply hard water.	A. Bypass valve is open or leaking B. No salt in brine tank. C. Injector plugged. D. Insufficient water flowing into brine tank. E. Leak at O-ring on riser pipe. F. Internal valve leak. G. Regeneration cycles not correct. H. Shortage of resin. I. Bad quality of feed water or turbine blocked.	A. Close or repair bypass valve. B. Add salt to brine tank and maintain salt level above water level. C. Change or clean injector. D. Check brine tank refill time. E. Make sure riser pipe is not cracked. Check o-ring and tube pilot. F. Change valve body. G. Set correct regeneration cycles in the program. H. Add resin to mineral tank and check whether resin leaks. I. Reduce the inlet turbidity, clean or replace turbine.
4. Softener fails to draw brine.	A. Line pressure is too low. B. Brine line is plugged. C. Brine line is leaking. D. Injector is plugged. E. Internal control leak. F. Drain line is plugged. G. Sizes of injector and DLFC not match with tank.	A. Increase line pressure. B. Clean brine line. C. Replace brine line. D. Clean or replace new parts. E. Replace valve body. F. Clean drain line flow control. G. Select correct injector size and DLFC according to the instruction requirements.
5. Unit used too much salt.	A. Improper salt setting. B. Excessive water in brine tank.	A. Check salt usage and salt setting. B. See problem no.6.

MODEL:F63D/F65D/F67D/F68D/F69D/F71D/F79D/F82D

Control Valve Fault (Continue)

<p>6. Excessive water in brine tank.</p>	<p>A. Overlong refilling time.                  B. Remain too much water after brine.                  C. Foreign material in brine valve and plug drain line flow control.                  D. Not install safety brine valve but power failure whiling salting.                  E. Safety brine valve breakdown.</p>	<p>A. Reset correct refilling time.                  B. Check the injector and make sure no stuff in the brine pipe.                  C. Clean brine valve and brine line.                  D. Stop water supplying and restart power and install safety brine valve in salt tank.                  E. Repair or replace safety brine valve.</p>
<p>7. Pressure lost or rust in pipeline</p>	<p>A. Iron in the water supply pipe.                  B. Iron mass in the softener.                  C. Fouled resin bed.                  D. Too much iron in the raw water.</p>	<p>A. Clean the water supply pipe.                  B. Clean valve and add resin cleaning chemical, increase frequency of regeneration.                  C. Check backwash, brine draw and brine tank refill. Increase frequency of regeneration and backwash time.                  D. Iron removal equipment is required to install before softening.</p>
<p>8. Loss of resin through drain line.</p>	<p>A. Air in water system.                  B. Bottom strainer broken.                  C. Improperly sized drain line control.</p>	<p>A. Assure that well system has proper air eliminator control.                  B. Replace new strainer.                  C. Check for proper drain rate.</p>
<p>9. Control cycle continuously.</p>	<p>A. Locating signal wiring breakdown.                  B. Controller is faulty.                  C. Foreign material stuck the driving gear.                  D. Time of regeneration steps were set to zero.</p>	<p>A. Check and connect locating signal wiring.                  B. Replace controller.                  C. Take out foreign material.                  D. Check program setting and reset.</p>
<p>10. Drain flows continuously.</p>	<p>A. Internal valve leak.                  B. When electricity fails to supply, valve stops backwash or rapid rinse position.</p>	<p>A. Check and repair valve body or replace it.                  B. Adjust valve to service position or turn off bypass valve and restart when electricity supply.</p>
<p>11. Interrupted or rregular brine.</p>	<p>A. Water pressure too low or not stable.                  B. Injector is plugged or faulty.                  C. Air in resin tank.                  D. Floccules in resin tank during backwash.</p>	<p>A. Increase water pressure.                  B. Clean or replace injector.                  C. Check and find the reason.                  D. Clean the floccules in resin tank.</p>
<p>12. Water flow out from drain or brine pipe after regeneration.</p>	<p>A. Foreign material in valve which makes valve can't be closed completely.                  B. Hard water mixed in valve body.                  C. Water pressure is too high which result in valve doesn't get the right position.                  D. Under the Backwash position, the outlet line and brine line are connected.</p>	<p>A. Clean foreign material in valve body.                  B. Change valve core or sealing ring.                  C. Reduce water pressure or use pressure release function.                  D. installs a check valve, solenoid valve in front of the outlet or installs a liquid level controller in the brine tank.</p>

MODEL:F63D/F65D/F67D/F68D/F69D/F71D/F79D/F82D

Control Valve Fault (Continue)

13. Salt water in soften water.	A. Foreign material in injector or injector fails to work. B. Brine valve cannot be shut-off. C. Time of rapid rinse too short.	A. Clean and repair injector. B. Repair brine valve and clean it. C. Extend rapid rinse time.
14. Unit capacity decreases.	A. Unit fails to regenerate or regenerate not properly. B. Fouled resin bed. C. Salt setting not proper. D. Softener setting not proper. E. Raw water quality deterioration. F. Turbine of flow meter is stuck.	A. Regenerate according to the correct operation requirement. B. Increase backwash flow rate and time, clean or change resin. C. Readjust brine drawing time. D. According to the test of outlet water, recount and reset. E. Regenerate unit by manual temporary, then reset regeneration cycle. F. Disassemble flow meter and clean it or replace a new turbine.

B. Controller Fault

Problem	Cause	Correction
1. All indicators display on front panel.	A. Wiring of front panel with controller fails to work. B. Control board is faulty. C. Transformer damaged. D. Electrical service not stable.	A. Check and replace the wiring. B. Replace control board. C. Check and replace transformer. D. Check and adjust electrical service.
2. No display on front panel.	A. Wiring of front panel with controller fails to work. B. Front panel damaged. C. Control board damaged. D. Electricity is interrupted.	A. Check and replace wiring. B. Replace front panel. C. Replace control board. D. Check electricity.
3. E1 Flash	A. Wiring of locating board with controller fails to work. B. Locating board damaged. C. Mechanical driven failure. D. Faulty control board. E. Wiring of motor with controller is fault. F. Motor damaged.	A. Replace wiring. B. Replace locating board. C. Check and repair mechanical part. D. Replace control board. E. Replace wiring. F. Replace motor.
4. E2 Flash	A. Hall component on locating board damaged. B. Wiring of locating board with controller fails to work. C. Control board is faulty.	A. Replace locating board. B. Replace wiring. C. Replace control board.
5. E3 or E4 Flash	A. Control board is faulty.	A. Replace control board.



MODEL:F63D/F65D/F67D/F68D/F69D/F71D/F79D/F82D

3.8. Assembly & Parts

F63 Flow Meter Connector & Animated Connector

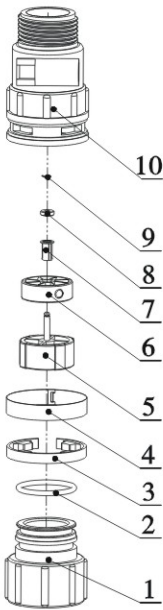

5447001 Flow Meter

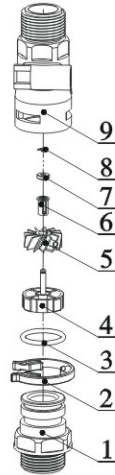

5457002 Animated Connector

5447001 Flow Meter			
Item No.	Description	Part No.	Quantity
1	Animated nut	8945001	1
2	O-ring 28 × 2.65	8378081	1
3	Clip	8270001	1
4	Ferrule	8270002	1
5	Impeller Supporter	5115001	1
6	Impeller	5436001	1
7	Rotate Core	8211001	1
8	Bushing	8210001	1
9	Spring Check Ring	8994005	1
10	Shell	8002001	1

5457002 Animated Connector			
Item No.	Description	Part No.	Quantity
1	Animated Nut	8945001	1
2	Ferrule	8270002	1
3	Clip	8270001	1
4	O-ring 28 × 2.65	8378081	1
5	Connector	8458038	1



# MODEL:F63D/F65D/F67D/F68D/F69D/F71D/F79D/F82D

## F65 Flow Meter Connector & Animated Connector

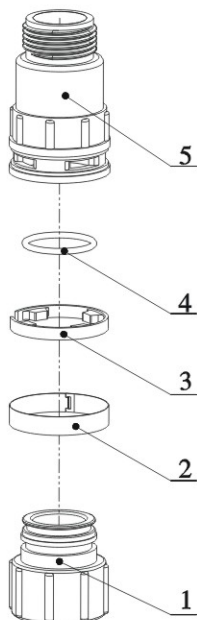

5447002 Flow Meter

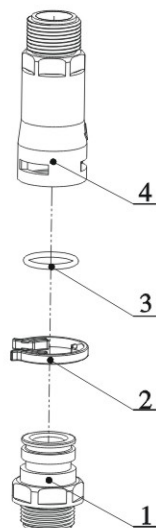

5457003 Animated Connector

5447002 Flow Meter			
Item No.	Description	Part No.	Quantity
1	Connector	8458014	1
2	Clip	8270005	1
3	O-ring 21.89 × 2.62	8378064	1
4	Impeller Supporter	5115003	1
5	Impeller	5436002	1
6	Rotate Core	8211001	1
7	Bushing	8210001	1
8	Spring Check Ring	8994005	1
9	Shell	8002006	1

5457003 Animated Connector			
Item No.	Description	Part No.	Quantity
1	Connector	8458014	1
2	Clip	8270005	1
3	O-ring 21.89 × 2.62	8378064	1
4	Connector	8458039	1

# MODEL:F63D/F65D/F67D/F68D/F69D/F71D/F79D/F82D

## F65D3 (62602) /F69D3 (72602) Valve Body Assembly

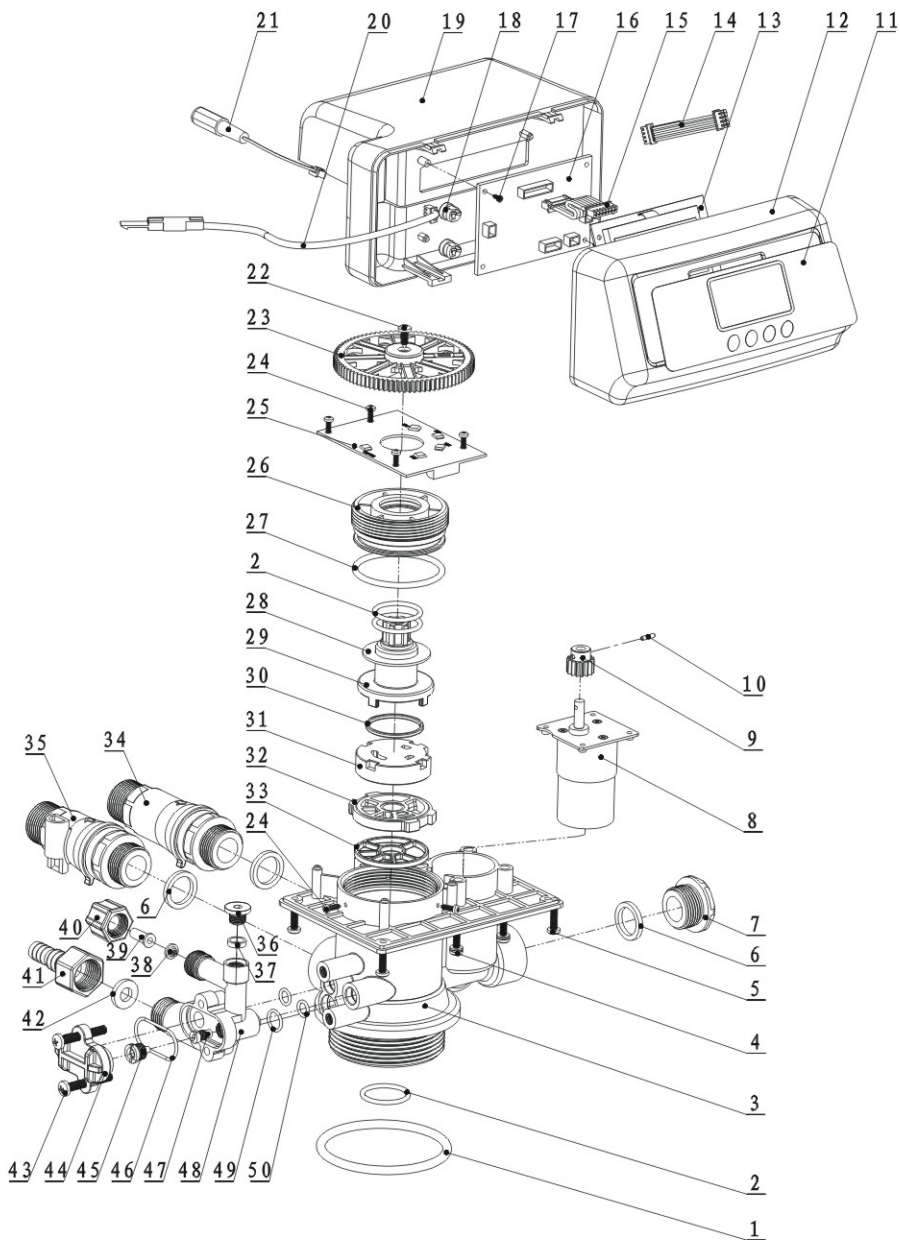

MODEL:F63D/F65D/F67D/F68D/F69D/F71D/F79D/F82D

**F65D1/F65D3 Valve Body Components (Item No.38, 39, 49 only for F65D3)**

Item No.	Description	Part No.	Quantity	Item No.	Description	Part No.	Quantity
1	O-ring73×5.3	8378143	1	26	Fitting Nut	8092007	1
2	O-ring25.8×2.65	8378078	1	27	O-ring50.39×3.53	8378107	1
3	Valve Body (ABS+GF10)	5022018	1	28	Anti-friction Washer	8216010	2
	Valve Body (PPO+GF20)	5022019		29	Shaft	8258009	2
4	Screw, Cross M4×30	8902009	4	30	Moving Seal Ring	8370053	1
5	Screw, Cross ST3.9×16	8909016	4	31	Moving Disk	8459013	1
6	Sealing Ring	8371019	3	32	Fixed Disk	8469012	1
7	Plug	8323005	1	33	Seal Ring	8370025	1
8	Motor	6158006	1	34	Animated Connector	5457003	1
9	Small Gear, Motor	8241010	1	35	Flow Meter	5447002	1
10	Pin	8993001	1	36	Plug	8323002	1
11	Label	8865013	1	37	Sealing Ring	8370003	1
12	Front Cover	8300004	1	38	Brine Line Flow Control	8468002	1
13	Display Board	6381006	1	39	Tube	8457004	1
14	Wire for Display Board	5512002	1	40	Nut, Hex. Hd	8940001	1
15	Wire for Locating Board	5511010	1	41	Joint	8458017	1
16	Control Board	6382043	1	42	Drain Line Flow Control	8468005	1
17	Screw, Cross ST2.2×6.5	8909004	2	43	Screw, Cross M5×35	8902017	2
18	Cable Clip	8126004	2	44	Cover, Injector	8315001	1
19	Dust Cover	8005005	1	45	Nozzle, Injector	8454005	1
20	Probe Wire	6386001	1	46	O-ring 30×1.8	8378025	1
21	Wire for power	5513001	1	47	Throat, Injector	8467005	1
22	Screw, Cross ST3.9×13	8909013	1	48	Injector Body	8008001	1
23	Gear	5241005	1	49	O-ring 10.82×1.78	8378012	1
24	Screw, Cross ST2.9×9.5	8909008	3	50	O-ring 7.5×1.8	8378016	2
25	Locating Board	6380003	1				

MODEL:F63D/F65D/F67D/F68D/F69D/F71D/F79D/F82D

F69D1/F69D3 Valve Body Components (Item No.38, 39, 40 only for F69D3)

Item No.	Description	Part No.	Quantity	Item No.	Description	Part No.	Quantity
1	O-ring 73×5.3	8378143	1	26	Fitting Nut	8092007	1
2	O-ring25.8×2.65	8378078	1	27	O-ring 50.39×3.53	8378107	1
3	Valve Body (ABS+GF10)	5022024	1	28	Anti-friction Washer	8216010	2
	Valve Body (PPO+GF20)	5022025		29	shaft	8258009	2
4	Screw, Cross M4×30	8902009	4	30	Moving Seal Ring	8370053	1
5	Screw, Cross ST3.9×16	8909016	4	31	Moving Disk	8459013	1
6	Sealing Ring	8371019	3	32	Fixed Disk	8469012	1
7	Plug	8323005	1	33	Sealing Ring	8370025	1
8	Motor	6158006	1	34	Animated Connector	5457003	1
9	Small gear, Motor	8241010	1	35	Flow Meter	5447002	1
10	Pin	8993001	1	36	Plug	8323002	1
11	Label	8865013	1	37	Sealing Ring	8370003	1
12	Front Cover	8300004	1	38	Brine Line Flow Control	8468002	1
13	Display Board	6381006	1	39	Tube	8457004	1
14	Wire for Display Board	5512002	1	40	Nut, Hex. Hd	8940001	1
15	Wire for Locating Board	5511010	1	41	Joint	8458017	1
16	Control Board	6382043	1	42	Drain Line Flow Control	8468005	1
17	Screw, Cross ST2.2×6.5	8909004	2	43	Screw, Cross M5×35	8902017	2
18	Cable Clip	8126004	2	44	Cover, Injector	8315001	1
19	Dust Cover	8005005	1	45	Nozzle, Injector	8454005	1
20	Probe Wire	6386001	1	46	O-ring 30×1.8	8378025	1
21	Wire for power	5513001	1	47	Throat, Injector	8467005	1
22	Screw, Cross ST3.9×13	8909013	1	48	Injector Body	8008001	1
23	Gear	5241005	1	49	O-ring 10.82×1.78	8378012	1
24	Screw, Cross ST2.9×9.5	8909008	3	50	O-ring 7.5×1.8	8378016	2
25	Locating Board	8380003	1				

# MODEL:F63D/F65D/F67D/F68D/F69D/F71D/F79D/F82D

## F63D3 (62604) /F68D3 (72604) Valve Body Assembly

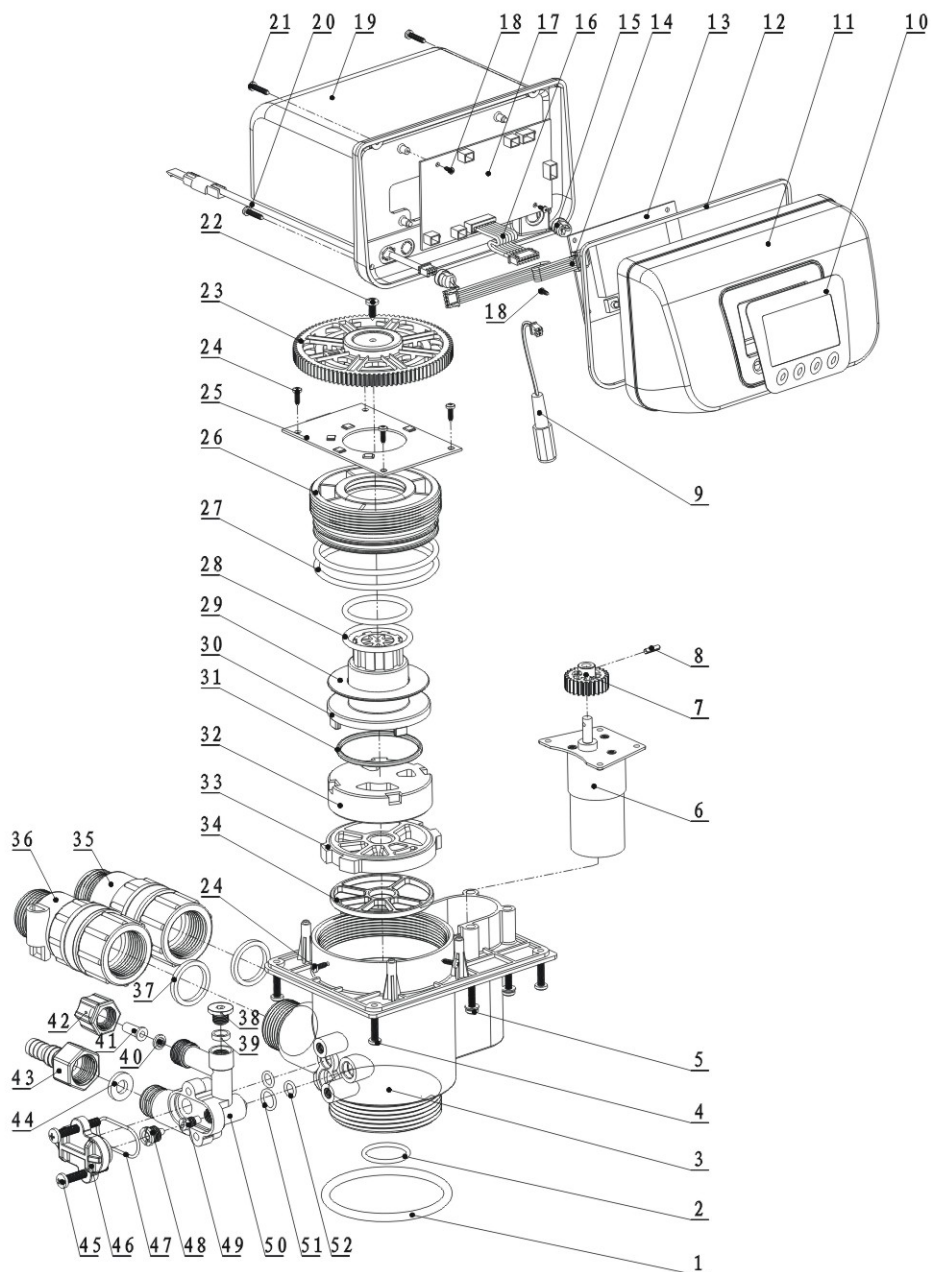



MODEL:F63D/F65D/F67D/F68D/F69D/F71D/F79D/F82D

F63D1/F63D3 Valve Body Components (Item No.20, 35, 36 only for F63D3)

Item No.	Description	Part No.	Quantity	Item No.	Description	Part No.	Quantity
1	O-ring 73×5.3	8378143	1	27	O-ring 73×3.55	8378128	2
2	O-ring 25.8×2.65	8378078	1	28	O-ring 37.7×3.55	8378118	2
3	Valve Body (ABS+GF10)	5022033	1	29	Anti-friction Washer	8216004	1
	Valve Body (PPO+GF20)	5022034		30	Shaft	8258004	1
4	Screw, Cross ST3.9×16	8909016	4	31	Moving Seal Ring	8370001	1
5	Screw, Cross M4×30	8902009	4	32	Moving Disk	8459001	1
6	Motor	6158011	1	33	Fixed Disk	8469001	1
7	Small gear, Motor	8241003	1	34	Sealing Ring	8370002	1
8	Pin	8993001	1	35	Animated Connector	5457002	1
9	Wire for Power	5513001	1	36	Flow Meter	5447001	1
10	Label	8865002	1	37	Sealing Ring	8371001	2
11	Front Cover	8300001	1	38	Plug	8323002	1
12	Sealing Ring	8371003	1	39	Sealing Ring	8370003	1
13	Display Board	6381003	1	40	Brine Line Flow Control	8468002	1
14	Wire for Display Board	5512001	1	41	Tube	8457004	1
15	Cable Clip	8126004	2	42	Nut, Hex. Hd	8940001	1
16	Wire for Locating Board	5511001	1	43	Joint	8458017	1
17	Control Board	6382003	1	44	Drain Line Flow Control	8468007	1
18	Screw, Cross ST2.2×6.5	8909004	4	45	Screw, Cross M5×35	8902017	2
19	Dust Cover	8005006	1	46	Cover, Injector	8315001	1
20	Probe Wire	6386001	1	47	O-ring 30×1.8	8378025	1
21	Screw, Cross ST2.9×16	8909010	4	48	Nozzle, Injector	8454009	1
22	Screw, Cross ST3.9×13	8909013	1	49	Throat, Injector	8467009	1
23	Gear	5241002	1	50	Injector Body	8008001	1
24	Screw, Cross ST2.9×9.5	8909008	7	51	O-ring.82×1.78	8378012	1
25	Locating Board	6380001	1	52	O-ring 7.5×1.8	8378016	2
26	Fitting Nut	8092004	1				

MODEL:F63D/F65D/F67D/F68D/F69D/F71D/F79D/F82D

F68D1/F68D3 Valve Body Components (Item No. 20, 35, 36 only for F68D3)

Item No.	Description	Part Number	Quantity	Item No.	Description	Part Number	Quantity
1	O-ring 73×5.3	8378143	1	27	O-ring73×3.55	8378128	2
2	O-ring25.8×2.65	8378078	1	28	O-ring37.7×3.55	8378118	2
3	Valve Body (ABS+GF10)	5022022	1	29	Anti-friction Washer	8216004	1
	Valve Body (PPO+GF20)	5022023		30	Shaft	8258004	1
4	Screw, Cross ST3.9×16	8902009	4	31	Moving Seal Ring	8371001	1
5	Screw, Cross M4×30	8909016	4	32	Moving Disk	8459015	1
6	Motor	6158011	1	33	Fixed Disk	8469014	1
7	Small gear, Motor	8243003	1	34	Sealing Ring	8370029	1
8	Pin	8993001	1	35	Animated Connector	5457002	1
9	Wire for Power	5513001	1	36	Flow Meter	5447001	1
10	Label	8865024	1	37	Sealing Ring	8458038	2
11	Front Cover	8300001	1	38	Plug	8323002	1
12	Sealing Ring	8371001	1	39	Sealing Ring	8370003	1
13	Display Board	6381006	1	40	Brine Line Flow Control	8468002	1
14	Wire for Display Board	5512002	1	41	Tube	8457004	1
15	Cable Clip	8126004	2	42	Nut,Hex.Hd	8940001	1
16	Wire for Locating Board	5511009	1	43	Joint	8458017	1
17	Control Board	6382043	1	44	Drain Line Flow Control	8468007	1
18	Screw, Cross ST2.2×6.5	8909004	4	45	Screw, Cross M5×35	8902017	2
19	Dust Cover	8005006	1	46	Cover, Injector	8315001	1
20	Probe Wire	6386001	1	47	O-ring 30×1.8	8454009	1
21	Screw, Cross ST2.9×16	8909010	4	48	Nozzle, Injector	8378025	1
22	Screw, Cross ST3.9×13	8909013	1	49	Throat, Injector	8467009	1
23	Gear	8241002	1	50	Injector Body	8008001	1
24	Screw Cross ST2.9×9.5	8909010	7	51	O-ring10.82×1.78	8378012	1
25	Locating Board	6380007	1	52	O-ring 7.5×1.8	8378016	2
26	Fitting Nut	8092004	1				

MODEL:F63D/F65D/F67D/F68D/F69D/F71D/F79D/F82D

F67D1 Valve Body Assembly

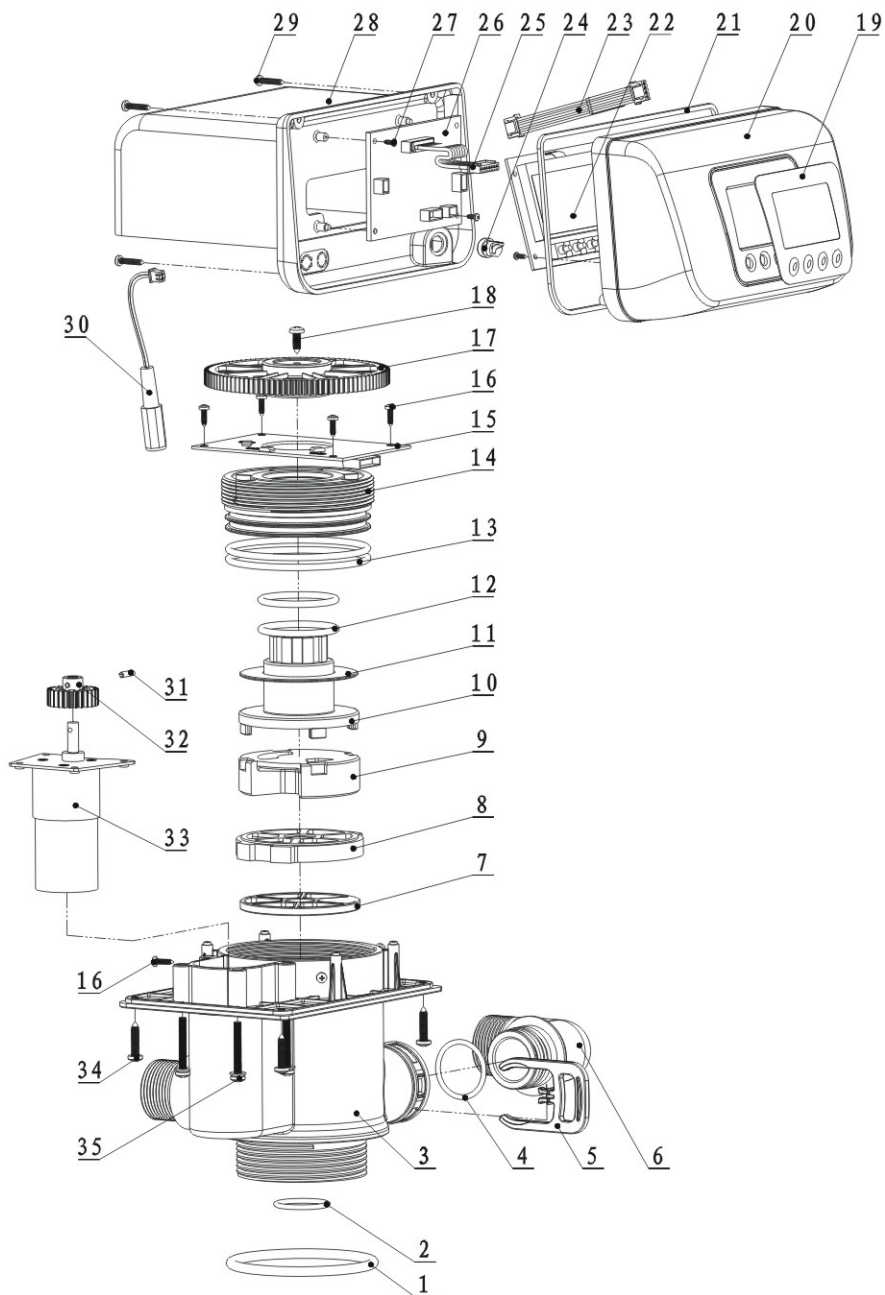

MODEL:F63D/F65D/F67D/F68D/F69D/F71D/F79D/F82D

F67D1 Valve Body Components

Item No.	Description	Part Number	Quantity	Item No.	Description	Part No.	Quantity
1	O-ring 73×5.3	8378143	1	19	Label	8865024	1
2	O-ring 25.8×2.65	8378078	1	20	Front Cover	8300001	1
3	Valve Body (ABS+GF10)	8022135	1	21	Sealing Ring	8371003	1
	Valve Body (PPO+GF20)	8022136		22	Display Board	6381006	1
4	O-ring 28×2.65	8378081	1	23	Wire for Display Board	5512002	1
5	Clip	8270004	1	24	Cable Clip	8126004	1
6	Elbow	8457034	1	25	Wire for Locating Board	5511008	1
7	Sealing Ring	8370027	1	26	Control Board	6382043	1
8	Moving Disk	8469013	3	27	Screw, Cross ST2.2×6.5	8909004	4
9	Fixed Disk	8459014	1	28	Dust Cover	8005006	1
10	Shaft	8258004	1	29	Screw, Cross ST2.9×16	8909010	4
11	Anti-friction Washer	8216004	1	30	Wire for Power	5513001	1
12	O-ring 37.7×3.55	8378118	1	31	Pin	8993001	1
13	O-ring 73×3.55	8378128	2	32	Small gear, Motor	8241003	1
14	Fitting Nut	8092007	2	33	Motor	6158011	1
15	Locating Board	6380008	1	34	Screw, Cross ST3.9×19	8909016	4
16	Screw, Cross ST2.9×9.5	8909008	7	35	Screw, Cross M4×30	8902009	4
17	Gear	5241002	1				
18	Screw, Cross ST3.9×13	8909013	1				

MODEL:F63D/F65D/F67D/F68D/F69D/F71D/F79D/F82D

F71D1 Valve Body Assembly

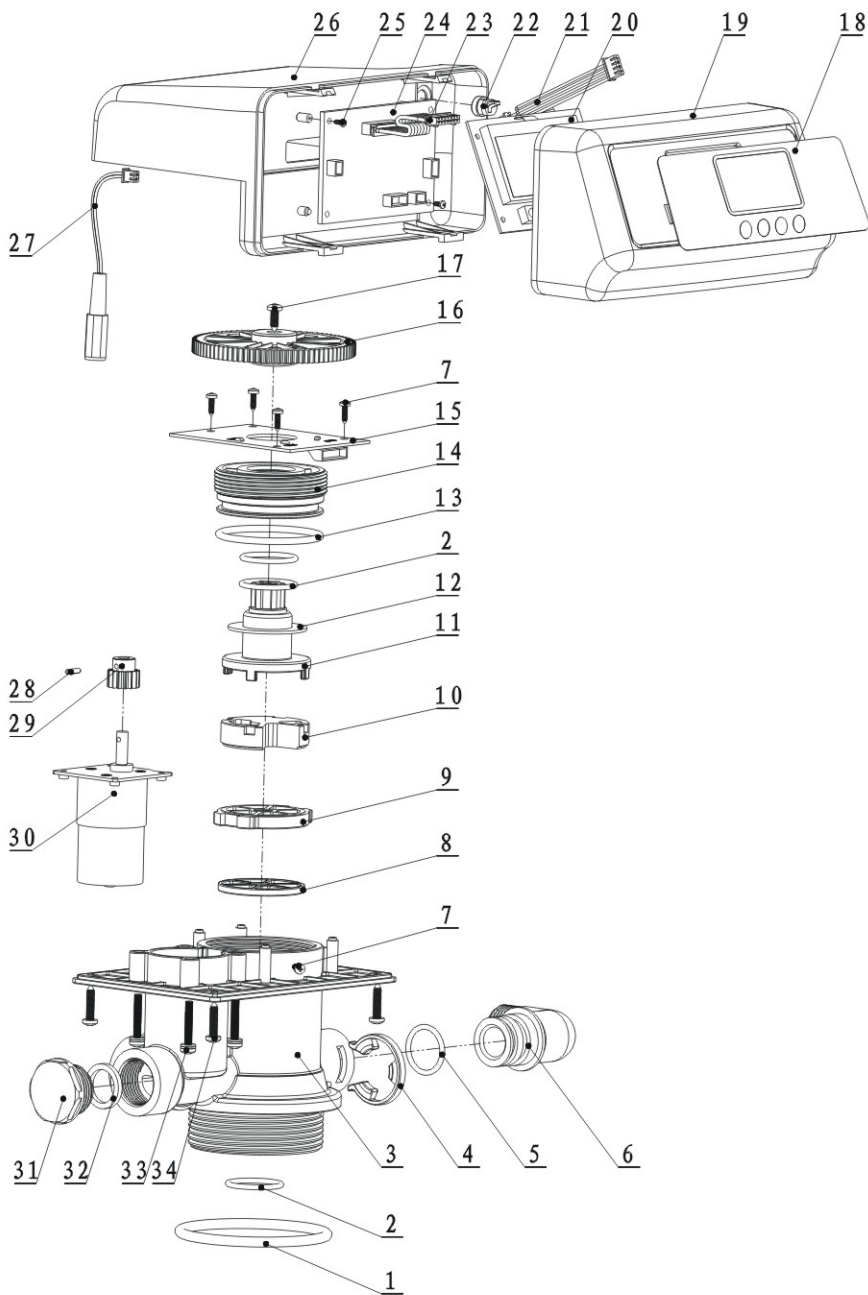



MODEL:F63D/F65D/F67D/F68D/F69D/F71D/F79D/F82D

F71D1 Valve Body Components

Item No.	Description	Part No.	Quantity	Item No.	Description	Part No.	Quantity
1	O-ring 73×5.3	8378143	1	18	Label	8865013	1
2	O-ring 25.8×2.65	8378078	3	19	Front Cover	8300004	1
3	Valve Body (ABS+GF10)	8022137	1	20	Display Board	6381006	1
	Valve Body (PPO+GF20)	8022138		21	Wire for Display Board	5512002	1
4	Clip	8270005	1	22	Cable Clip	8126004	1
5	O-ring 21.89×2.62	8378064	1	23	Wire for Locating Board	5511008	1
6	Elbow	8457035	1	24	Control Board	6382043	1
7	Screw, Cross ST2.9×9.5	8909008	7	25	Screw, Cross ST2.2×6.5	8909004	2
8	Sealing Ring	8370038	1	26	Dust Cover	8005025	1
9	Fixed Disk	8469018	1	27	Wire for Power	5513001	1
10	Moving Disk	8459019	1	28	Pin	8993001	1
11	Shaft	8258009	1	29	Small gear, Motor	8241010	1
12	Anti-friction Washer	8216010	1	30	Motor	6158006	1
13	O-ring 50.39×3.53	8378107	1	31	Plug	8323005	1
14	Fitting Nut	8092007	1	32	Sealing Ring	8371019	1
15	Locating Board	6380023	1	33	Screw, Cross M4×30	8902009	4
16	Gear	5241005	1	34	Screw, Cross ST3.9×19	8909016	4
17	Screw, Cross ST3.9×13	8909013	1				

MODEL:F63D/F65D/F67D/F68D/F69D/F71D/F79D/F82D

F79AD Valve Body Assembly

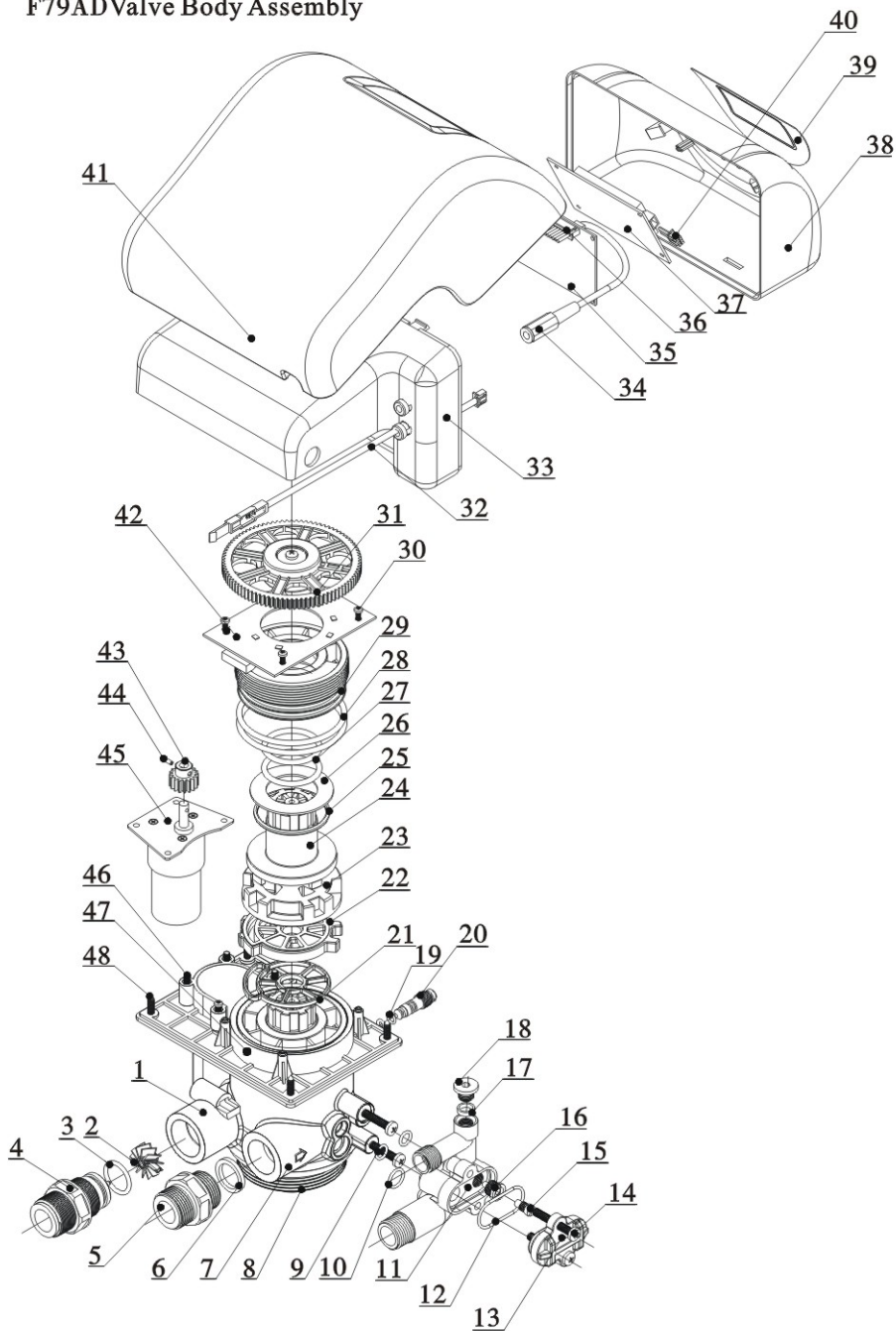

MODEL:F63D/F65D/F67D/F68D/F69D/F71D/F79D/F82D

F79AD Valve Body Components

Item No.	Description	Part No.	Quantity
1	Valve Body	5022029	1
2	Impeller	5436007	1
3	O-ring	8378074	1
4	Flow Meter Connector	8458026	1
5	Animated Connector	8458001	1
6	Sealing Ring	8371019	1
7	O-ring	8378143	1
8	O-ring	8378078	1
9	O-ring	8378016	2
10	O-ring	8378012	1
11	Injector Body	8008001	1
12	O-ring	8378025	1
13	Cover of Injector	8315001	1
14	Screw, Cross	8902017	2
15	Throat, Injector	8467001	1
16	Nozzle, Injector	8454001	1
17	Seal Ring	8370003	1
18	Plug	8323002	1
19	O-ring	8378003	3
20	Adjusting Bolt	8906002	1
21	Sealing Ring	8370046	1
22	Fixed Disk	8469024	1
23	Moving Disk	8459026	1
24	Shaft	8258013	1

Item No.	Description	Part No.	Quantity
25	Moving Seal Ring	8370064	1
26	Anti-friction Washer	8216011	1
27	O-ring	8378116	2
28	O-ring	8378126	2
29	Fitting Nut	8092011	1
30	Screw, Cross	8909008	4
31	Gear	8241009	1
32	Probe Wire	6386001	1
33	Dust Cover	8005013	1
34	Wire for Power	5513001	1
35	Control Board	6382043	1
36	Wire for Locating Board	5511004	1
37	Display Board	6381006	1
38	Front Cover	8300008	1
39	Label	8865014	1
40	Wire for Display Board	5512002	1
41	Dust Cover	8300015	1
42	Locating Board	6380011	1
43	Small Gear, Motor	8241015	1
44	Pin	8993001	1
45	Motor	6158026	1
46	Screw, Cross	8902008	4
47	Screw, Cross	8909008	4
48	Screw, Cross	8909016	4

MODEL:F63D/F65D/F67D/F68D/F69D/F71D/F79D/F82D

F79BD Valve Body Assembly and Components

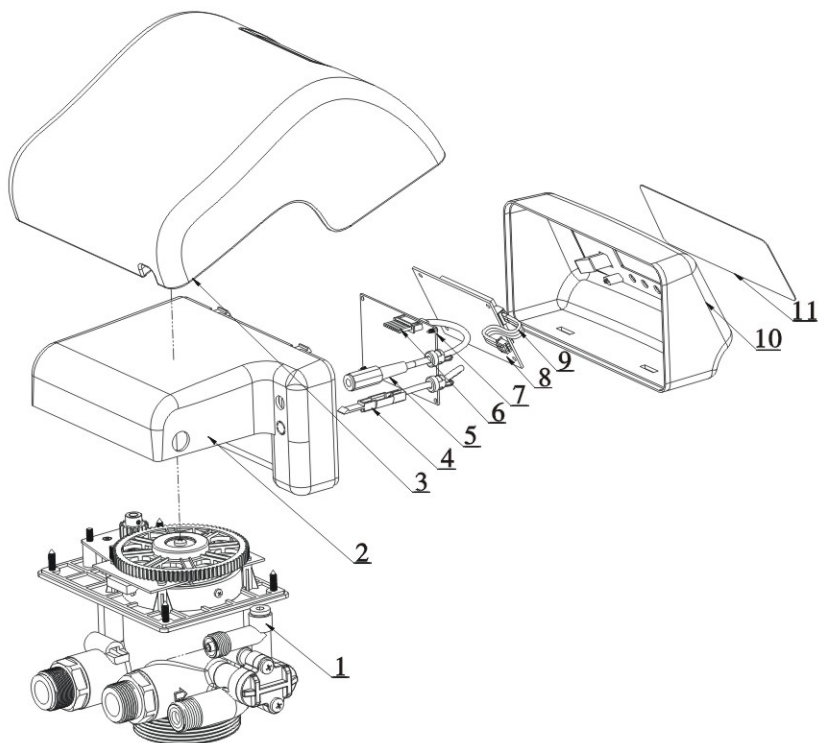

Item No.	Description	Part No.	Quantity	Remark
1	Control Valve Mechanism	6794013	1	It has the same parts as 83602 product, except for the moving disk(459027)
2	Dust Cover	8005014	1	/
3	Dust Cover	8300015	1	/
4	Probe Wire	6386001	1	/
5	Wire for Power	8513003	1	/
6	Wire for Locating Board	5511004	1	/
7	Control Board	6382043	1	/
8	Display Board	6381006	1	/
9	Wire for Display Board	5512002	1	/
10	Front Cover	8300004	1	/
11	Label	8865013	1	/

MODEL:F63D/F65D/F67D/F68D/F69D/F71D/F79D/F82D

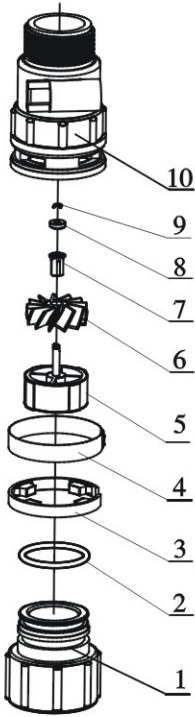

5447007 Flow Meter

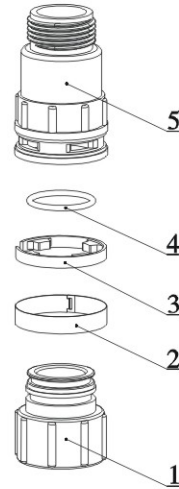

5457002 Animated Connector

5447007 Flow Meter			
Item No.	Description	Part No.	Quantity
1	Animated nut	8945001	1
2	O-ring 28×2.65	8378081	1
3	Clip	8270001	1
4	Ferrule	8270002	1
5	Impeller Supporter	5115001	1
6	Impeller	5436004	1
7	Rotate Core	8211002	1
8	Bushing	8210001	1
9	Spring Check Ring	8994005	1
10	Shell	8002001	1

5457002 Animated Connector			
Item No.	Description	Part No.	Quantity
1	Animated nut	8945001	1
2	Ferrule	8270002	1
3	Clip	8270001	1
4	O-ring 28×2.65	8378081	1
5	Connector	8458038	1



MODEL:F63D/F65D/F67D/F68D/F69D/F71D/F79D/F82D

F82AD3 & F82BD3 Valve Body Assembly

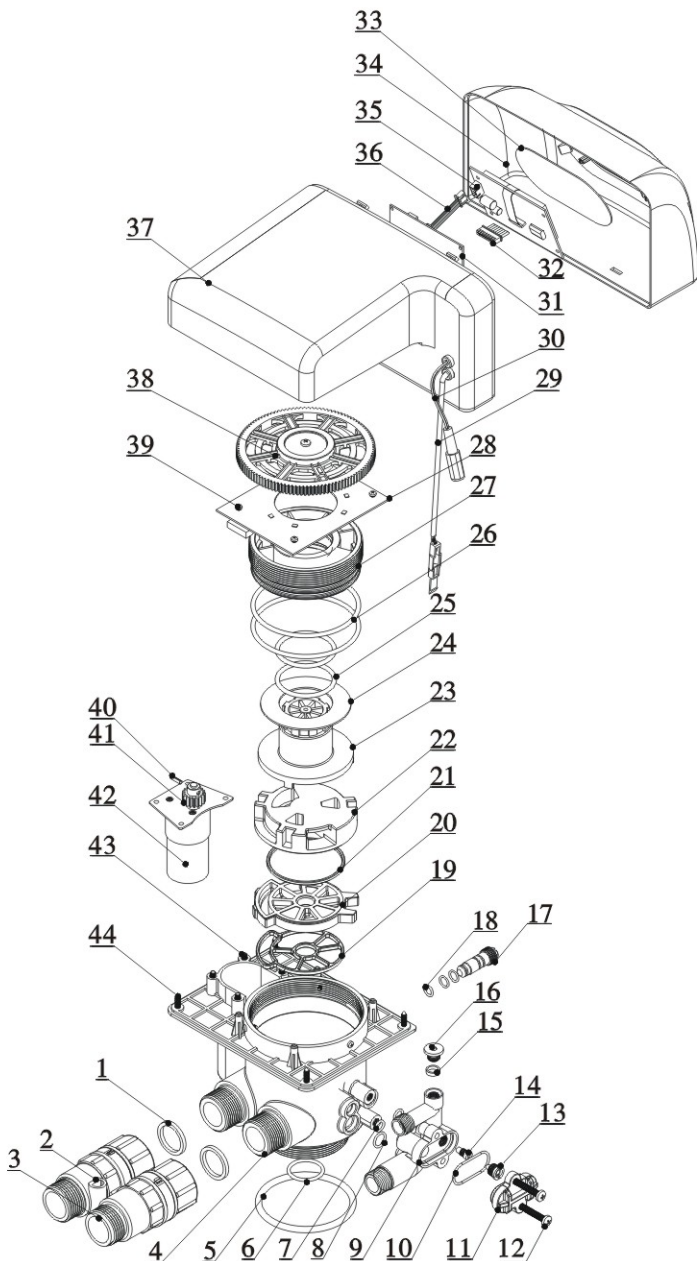

MODEL:F63D/F65D/F67D/F68D/F69D/F71D/F79D/F82D

F82AD3, F82AD1, F82BD3, F82BD1 Valve Body Assembly and Components

Item No.	Description	Part No.				Quantity
		F82AD1	F82AD3	F82BD1	F82BD3	
1	Sealing Ring	/	8371001	/	8371001	2
2	Flow Meter	/	5447007	/	5447007	1
3	Animated Connector	/	5457002	/	5457002	1
4	Valve Body	5022030	5022030	5022030	5022030	1
5	O-ring	8378143	8378143	8378143	8378143	1
6	O-ring	8378078	8378078	8378078	8378078	1
7	O-ring	8378016	8378016	8378016	8378016	2
8	O-ring	8378012	8378012	8378012	8378012	1
9	Injector Body	8008001	8008001	8008001	8008001	1
10	O-ring	8378025	8378025	8378025	8378025	1
11	Cover, Injector	8345001	8345001	8345001	8345001	1
12	Screw, Cross	8902017	8902017	8902017	8902017	2
13	Nozzle, Injector	8454001	8454001	8454001	8454001	1
14	Throat, Injector	8467001	8467001	8467001	8467001	1
15	Sealing Ring	8370003	8370003	8370003	8370003	1
16	Plug	8323002	8323002	8323002	8323002	1
17	Bypass Adjusting Bolt	8906003	8906003	8906003	8906003	1
18	O-ring	8378004	8378004	8378004	8378004	3
19	Sealing Ring	8370049	8370049	8370049	8370049	1
20	Fixed Disk	8469026	8469026	8469026	8469026	1
21	Moving Sealing Ring	8370065	8370065	8370065	8370065	1
22	Moving Disk	8459029	8459029	8459030	8459030	1
23	Shaft	8258014	8258014	8258014	8258014	1
24	Anti-friction Washer	8216012	8216012	8216012	8216012	1
25	O-ring	8378123	8378123	8378123	8378123	2

MODEL:F63D/F65D/F67D/F68D/F69D/F71D/F79D/F82D

26	O-ring	8378102	8378102	8378102	8378102	2
27	Fitting Nut	8092012	8092012	8092012	8092012	1
28	Locating Board	6380012	6380012	6380012	6380012	1
29	Probe Wire	/	6386001	/	6386001	1
30	Wire for Power	5513003	5513003	5513003	5513003	1
31	Control Board	6382043	6382043	6382043	6382043	1
32	Wire for Locating Board	5511004	5511004	5511004	5511004	1
33	Label	8865016	8865016	8865007	8865007	1
34	Front Cover	8300017	8300017	8300007	8300007	1
35	Display Board	6381006	6381006	6381006	6381006	1
36	Wire for Display Board	5512002	5512002	5512002	5512002	1
37	Dust Cover	8005016	8005016	8005016	8005016	1
38	Gear	5241011	5241011	5241011	5241011	1
39	Screw, Cross	8909016	8909016	8909016	8909016	1
40	Pin	8993003	8993003	8993003	8993003	1
41	Small Gear, Motor	8241015	8241015	8241015	8241015	1
42	Motor	6158011	6158011	6158011	6158011	1
43	Screw, Cross	8902008	8902008	8902008	8902008	4
44	Screw, Cross	8909016	8909016	8909016	8909016	4

## 4.Warranty Card

Dear client:

This warranty card is the guarantee proof of RUNXIN brand multi-functional flow control valve. It is kept by client self. You could get the after-sales services from the supplier which is appointed by RUNXIN manufacturer. Please keep it properly. It couldn't be retrieved if lost. It couldn't be repaired free of charge under the below conditions:

1. Guarantee period expired.(One year);
2. Damage resulting from using, maintenance, and keeping that are not in accordance with the instruction;
3. Damage resulting from repairing not by the appointed maintenance personnel;
4. Content in guarantee proof is unconfirmed with the label on the real good or be altered;
5. Damage resulting from force majeure.

Product Name	 <b>润新</b> RUNXIN	Multi-functional Flow Control Valve for Water Treatment Systems			
Model		Code of Valve Body			
Purchase Company Name		Tel/Cel.			
Problem					
Solution					
Date of Repairing		Date of Accomplishment		Maintenance Man Signature	

When product need warranty service, please fill in the below content and sent this card together with the product to the appointed suppliers or Runxin company.

End-user Company Name		Tel/Cel.		
Purchase Company Name		Tel/Cel.		
Model		Code of Valve Body		
Tank Size $\phi$ ×		Resin Tank Size L	Raw Water Hardness	mmol/L
Water Source: Ground-water <input type="checkbox"/> Tap Water <input type="checkbox"/>		Water Treatment Capacity	Backwash Time	min
Brine & Slow Rinse Time min		Brine Refill Time min	Fast Rinse Time	min
Problem Description				



---

**WENZHOU RUNXIN MANUFACTURING MACHINE CO.,LTD**

ADD: Jinger Road, Shatou Group, Linjiang, Lucheng District, Wenzhou, Zhejiang, China

Tel: +86-577-88635628 88630038 Fax: +86-0577-88633258

Http://www.run-xin.com Email:sales@run-xin.com